

- ③ GPIO00-06
 - JTAG:GPIO0-4
 - UART0:GPIO5,6
- ④ GPIO07-20
 - HDMI:GPIO7,8 (DDC I2C-CLK, SDA)
 - JATG:GPIO9-13 (HIFI4)
 - DSI:GPIO9,10 (I2C)
 - DSI:RGPIO11,12 (CS, TX)
 - DSI:GPIO11,12 (CLK, GPIO-unused)
 - GMAC:GPIO13 (RST)
 - HDMI:GPIO14,15 (CEC, HPD)
 - CSI:GPIO16,17,18 (I2C, GPIO-unused)
 - PMIC:GPIO19,20 (I2C)
 - PMIC:RGPIO2
 - DVP:GPIO12,18 (I2C)
- ⑤ GPIO21-35
 - QSPI/PCIe0:GPIO21 (CS1)
 - SDIO0:GPIO22 (EMMC RST)
 - SDIO0:GPIO23,24,25 (SD DET,RST,VDD_SD_SEL)
 - PCIe1:GPIO26,27 (PERST, PRSN)
 - PCIe0:GPIO28,29 (PERST, PRSN)
 - UART3:GPIO30,31
 - CAN:GPIO30,31 (Jump to UART3)
 - CAN/PCIe1:GPIO32
 - USB3.0:GPIO33,34 (OC,DIR)
 - LED:GPIO35
 - DVP TEST:GPIO21..35
- ⑥ GPIO36-63
 - RVPI:GPIO36..63
 - TPs:GPIO36..63
 - Funs TEST:GPIO36..63
 - LCD TEST:GPIO36..63
 - Trace:GPIO59..63

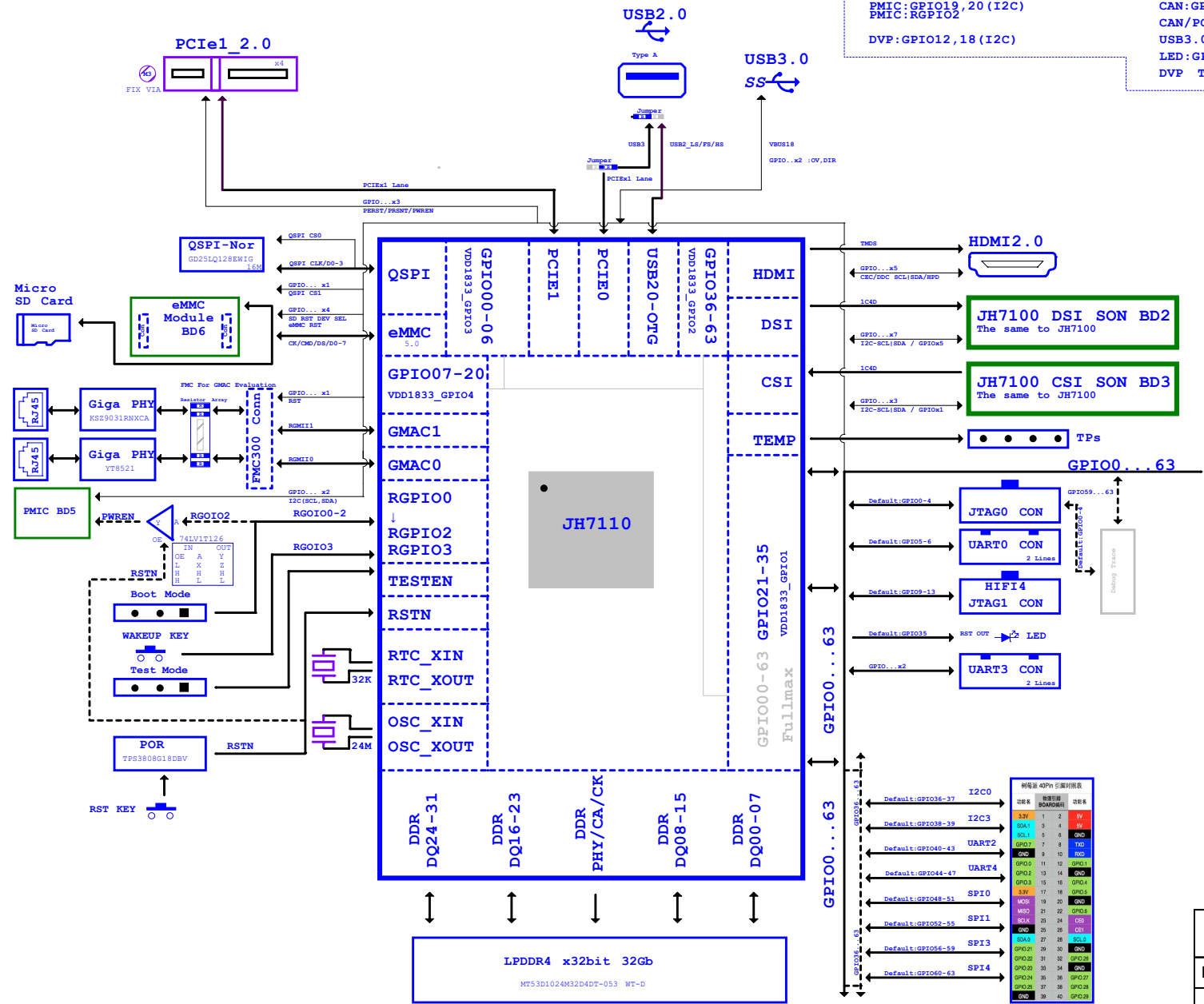

利海英 40Pin 引脚列表表

功能名称	引脚名称	引脚号	电压
I2C0	Default:GPIO36-37	36, 37	3.3V
I2C3	Default:GPIO38-39	38, 39	3.3V
UART2	Default:GPIO40-43	40, 41, 42, 43	3.3V
UART4	Default:GPIO44-47	44, 45, 46, 47	3.3V
SPI0	Default:GPIO48-51	48, 49, 50, 51	3.3V
SPI1	Default:GPIO52-55	52, 53, 54, 55	3.3V
SPI3	Default:GPIO56-59	56, 57, 58, 59	3.3V
SPI4	Default:GPIO60-63	60, 61, 62, 63	3.3V

PINE64

Project: Star64 Schematic ver1.0-20220721

File: Star64_Schematic_V1.0_20220721

Date: Thursday, July 21, 2022

Designed by: Vamrs Tech

Rev: V1.0

Sheet: of

JH7110 Power sequence on PCB

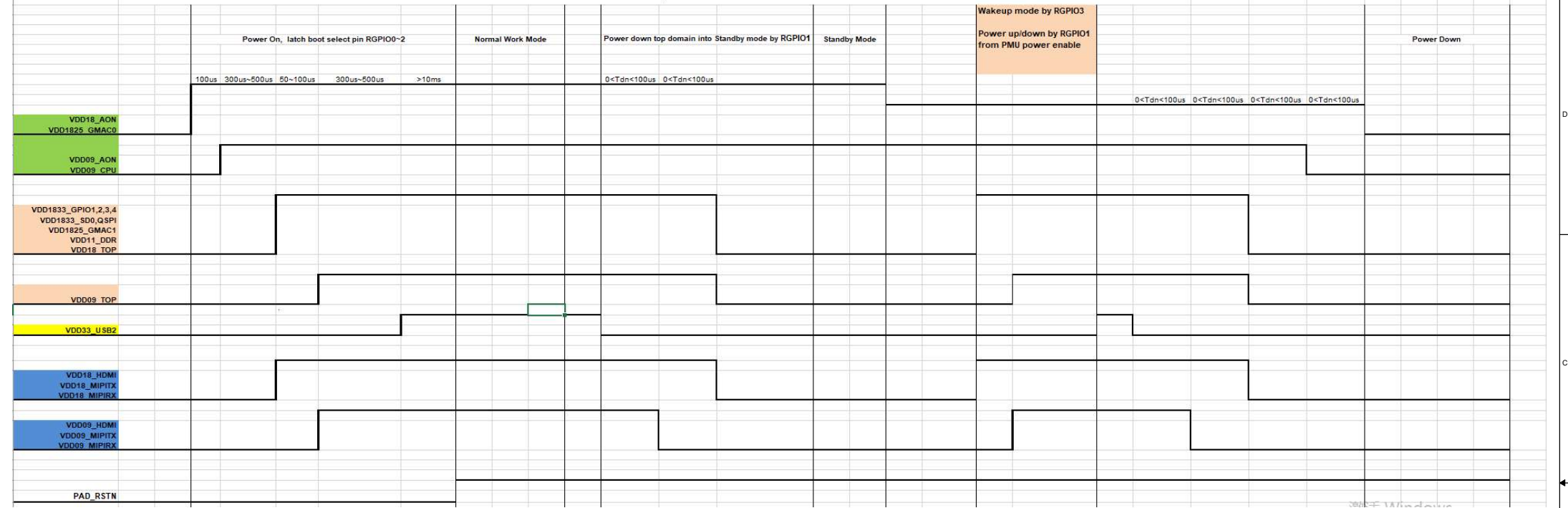

Group	Power pin in PMIC	Package Ball Name	Power pin index	Voltage (V)	Comments
Green	VDD09_AON	VDD_RTC	1	0.9	In standby mode, always on power domain, turn off other power domain
		VDD_CFU	2	0.9-1.0	CPU core supply can adj to 1.0V. Note: 0.9V VDD_CPMU ID
Red	VDD09_CPU	VDD18_GSC	3	1.8	always on domain GPIO, RPIC, RESETN, TESTEN, 1.8v only
		VDD18_OFF			
		VDD1833_GPI01,2,3,4			
Green	VDD18_AON	VDD1825_GMAC0	4	1.8/2.5	GMACO IO Power domain, 1.8V/2.5V, Always on.
		VDD18_HDMI	5	1.8	HDMI & MIPIRX 1.8v analog power supply, Power on first
Blue	VDD09_HDMI	AVDD09_HDMI	6	0.9	0.9V power on after VDD18_HDMI_MIPIRX, VDD09_HDMI and VOUT digital turn on/off together
		PVDD_HDMI			
		VCC18A_MIPIRX	7	1.8	
Blue	VDD09_MIPIRX	VDD09_MIPIRX	8	0.9	MIPI RX 1.8v analog power supply, power on first
		VCC18A_MIPIRX	9	1.8	
		VCC09A_MIPIRX	10	0.9	
Blue	VDD09_MIPIRX	VCC09A_MIPIRX	10	0.9	MIPI RX 0.9v power supply, power on after VDD18_MIPIRX
		VCC33_USB	11	3.3	
		VCC09_USB	12	0.9	
AVDD09_USB					
AVDD_PCIE0					
AVDD_PCIE1					
VDD_PLL0					
VDD_PLL1					
VDD_PLL2					
VDD_DDR					
VDDPLL_DDR					
VCC18B_PLL0	13	1.8			VCC18B_PLL0 VCC18B_PLL1 VDD18_TEMP VCC18B_TEMP VCC18B_PLL2 AVDD_PCIE0 AVDD_PCIE1 VCC18B_USB
VCC18B_PLL1					
VDD18_TEMP					
VCC18B_TEMP					
VCC18B_PLL2					
Blue	VDDQ11_DDR	VDDQ_DDR	14	1.1	DDRPHY IO and CLK IO voltage, 1.1v
		VDDQCK_DDR			
Orange	VDD1833_GPI01	VDD1833_GPI01	15	1.8/3.3	
		VDD1833_GPI02			
		VDD1833_GPI03			
		VDD1833_GPI04			
Orange	VDD1833_QSPI	VDD1833_QSPI	16	1.8/2.5	
		VDD1833_QSPI			
		VDD1833_QSPI			
Orange	VDD1825_GMAC1	VDD1825_GMAC1	17	1.8/2.5	
		VDD1825_GMAC1			

See the JH7110_Package_spec Excel for details.

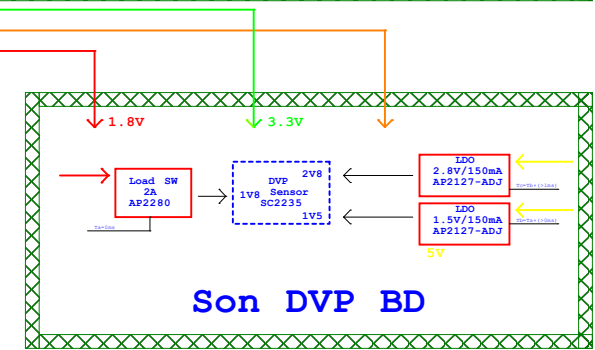
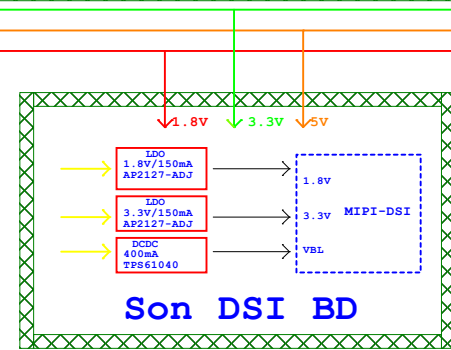
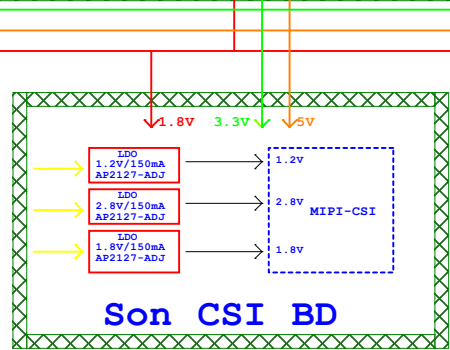
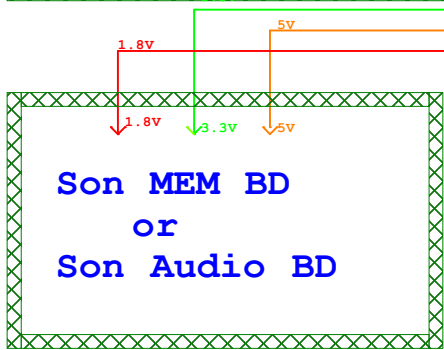
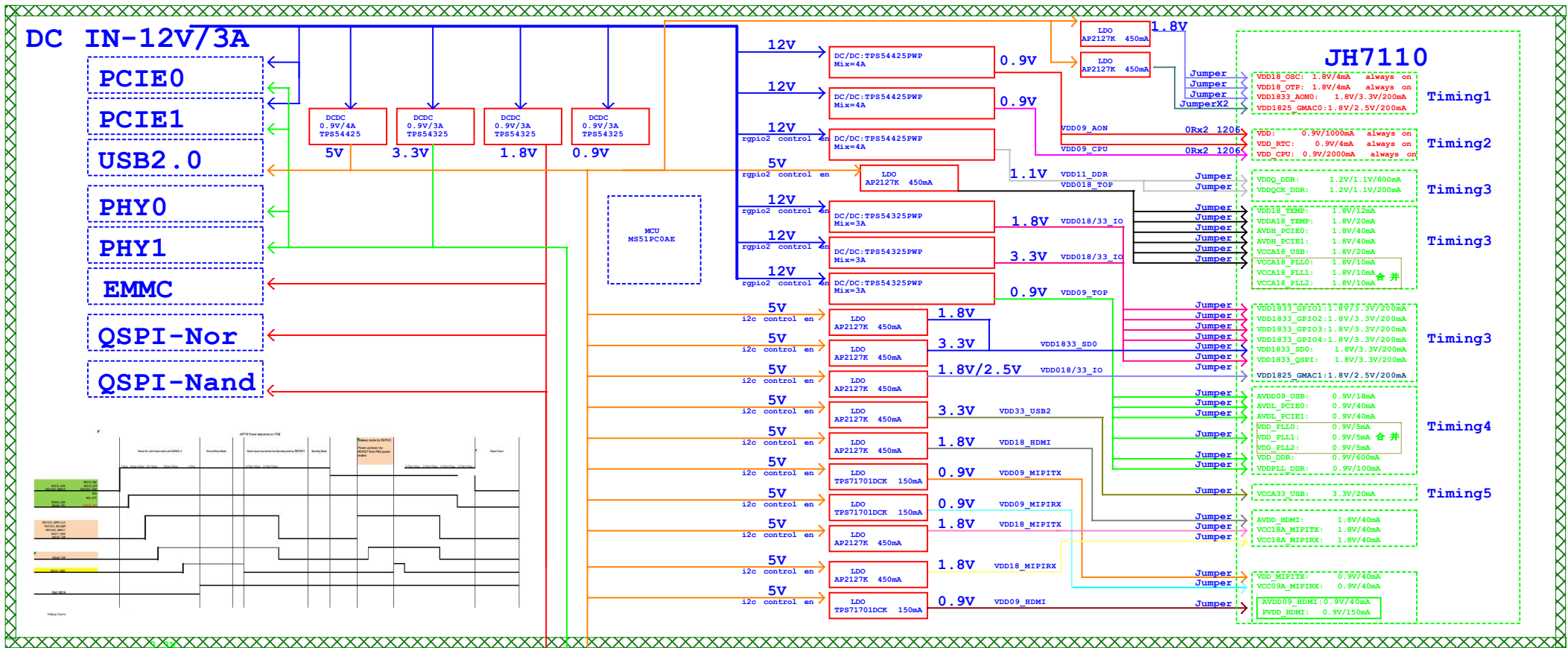

PAGE LIST

- PAGE00: Diagram-SYSTEM
- PAGE01: Diagram-PD SEQ
- PAGE02: Diagram PD
- PAGE03: Diagram-GPIOs List
- PAGE04: History
- PAGE05: JH7110 Power
- PAGE06: JH7110 DDR Ctrl
- PAGE07: JH7110 GMAC0&1
- PAGE08: JH7110 EMMC&QSPI
- PAGE09: JH7110 GPIOs
- PAGE10: JH7110 HIFs
- PAGE11: JH7110 SYS&OSC&TEMP
- PAGE12: LPDDR4 RAM
- PAGE13: GMAC0 PHY
- PAGE14: GMAC1 PHY
- PAGE15: MIPI CSI
- PAGE16: MIPI DSI
- PAGE17: PCIe
- PAGE18: Digital Video
- PAGE19: eMMC & SD
- PAGE20: Power
- PAGE21: PMU
- PAGE22: Power Distribution 0
- PAGE23: Power Distribution 1
- PAGE24: USB Hub 0
- PAGE25: USB Hub 1
- PAGE26: USB Ports
- PAGE27: USB Wifi Module
- PAGE28: 40 pin GPIO Bus

GPIO List

Power Group	GPIO Name	Default FUN	Default Jumper	Default Devices (ALL ON J57)	EXT Jumper Function			
VDD1833_GPIO3	GPIO00	U7MC JTAG TCK	J17 & J18	J37(JTAG CON)				
	GPIO01	U7MC JTAG TDI						
	GPIO02	U7MC JTAG TMS						
	GPIO03	U7MC JTAG TDO						
	GPIO04	U7MC JTAG TRSTN						
	GPIO05	UART0 TX						
	GPIO06	UART0 RX	J21 & J22	J38(UART CON)				
VDD1833_GPIO4	GPIO07	HDMI I2C_SCL	J26 & J27	CN1(HDMI CON)				
	GPIO08	HDMI I2C_SDA						
	GPIO09	DSI I2C_SDA						
	GPIO10	DSI GPIO	J24 & J23	J6(DSI CON)		J24 & J25 J43(FIH14_JTAG_TCK)		
	GPIO11	DSI I2C_SCL				J24 & J25 J43(FIH14_JTAG_TDI)		
	GPIO12					J24 & J25 J43(FIH14_JTAG_TDO)		
		GPIO13	GMAC PHYRSTN	R237		U6,7(GMAC PHYRSTN)	J24 & J25 J43(FIH14_JTAG_TMS)	
		GPIO14	HDMI CEC GPIO	J26 & J27			J36 J54(DVP I2C_SDA)	
		GPIO15	HDMI HPDIN			CN1(HDMI CON)		
		GPIO16	CSI I2C_SCL	J28 & J29		J5(CSI CON)		
		GPIO17	CSI I2C_SDA					
		GPIO18	CSI GPIO					
	GPIO19	PMIC I2C_SCL	J32 & J33	U26(PMIC Module)	J36 J54(DVP I2C_SCL)			
	GPIO20	PMIC I2C_SDA						
VDD1833_GPIO1	GPIO21	PCIE1 PWREN H	J15	U32(PCIE1 PWREN)	J16 U3(QSPI Flash CS)			
	GPIO22	SDIO0 RSTN						
	GPIO23	SD DET N						
	GPIO24	SD RST N	J16	J10(eMMC Module)				
	GPIO25	SD SEL18_EN						
	GPIO26	PCIE0 PERSTN						
		GPIO27	PCIE0 PRSN	J19				U11(PCIE0 CON)
		GPIO28	PCIE1 PERSTN					
		GPIO29	PCIE1 PRSN					
		GPIO30	UART3 TX	J20			U42(UART CON)	J104 U22(CAN0_TXD)
		GPIO31	UART3_RX					J105 U22(CAN0_RXD)
		GPIO32	PCIE0 PWREN H					U33(PCIE1 PWREN)
		GPIO33	USB VBUS DIR				U10(USB PWR)	
		GPIO34	USB OC					
		GPIO35	WTD RSTOUT					
VDD1833_GPIO2	GPIO36			J55				
	GPIO37							
	GPIO38							
	GPIO39							
	GPIO40							
	GPIO41							
	GPIO42							
	GPIO43							
	GPIO44							
	GPIO45							
	GPIO46							
	GPIO47							
	GPIO48							
	GPIO49							
	GPIO50							
	GPIO51							
	GPIO52							
	GPIO53							
	GPIO54							
	GPIO55							
	GPIO56							
GPIO57								
GPIO58								
GPIO59								
GPIO60								
GPIO61								
GPIO62								
GPIO63								
VDD18_AON	RGPI00	Boot Mode	J44	(NOT ON J57)	J6(DSI CON)			
	RGPI01	Boot Mode	J41		J6(DSI CON)			
	RGPI02	Boot Mode	J40		U26(PMIC WAKEUP)			

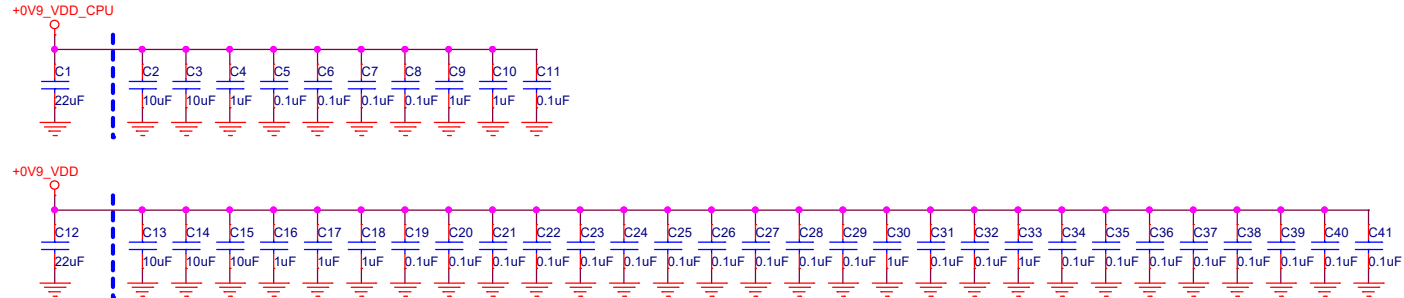
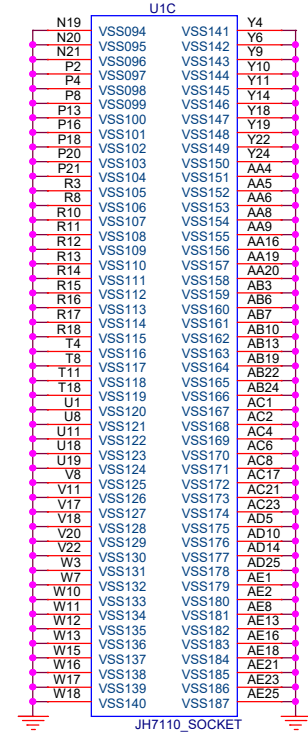
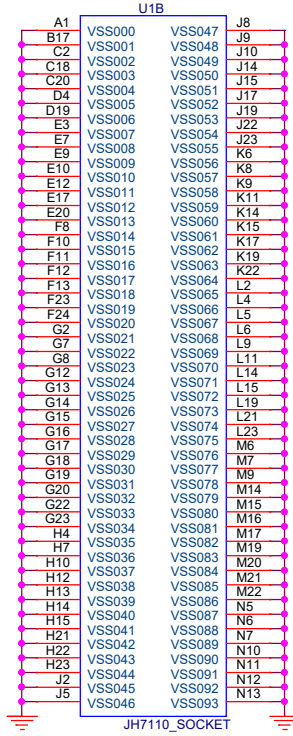
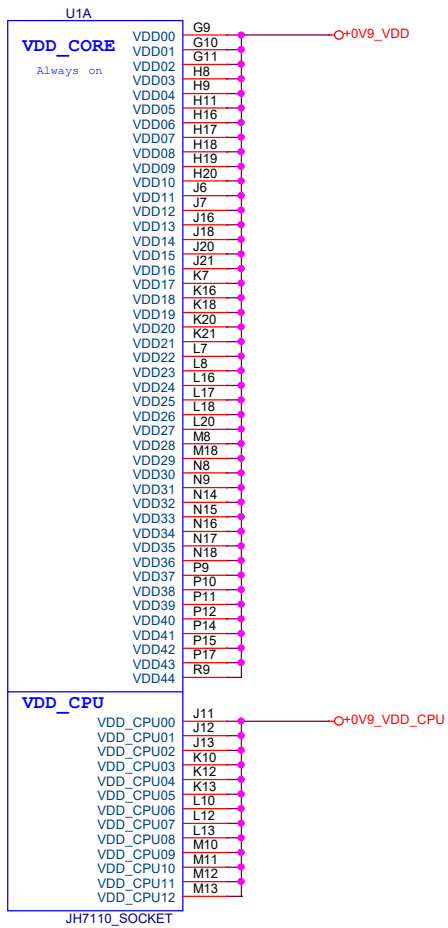

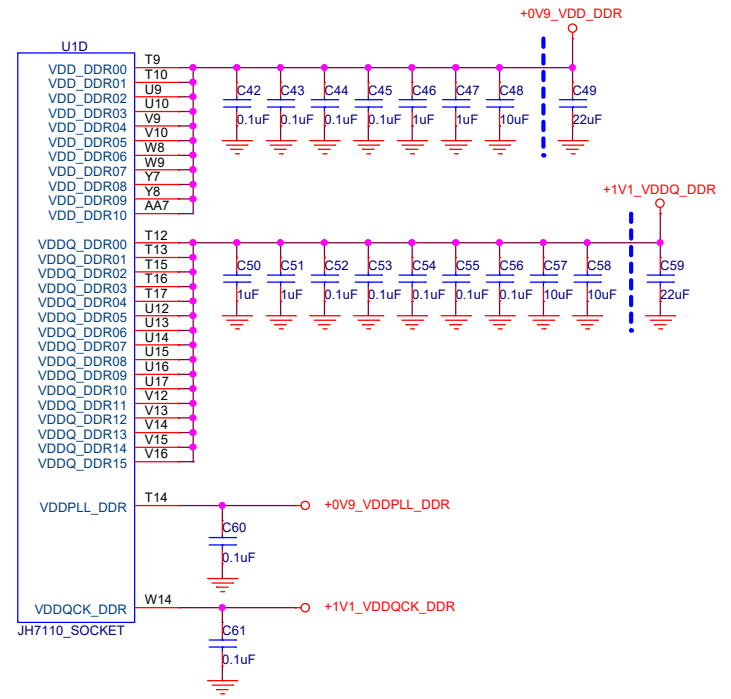
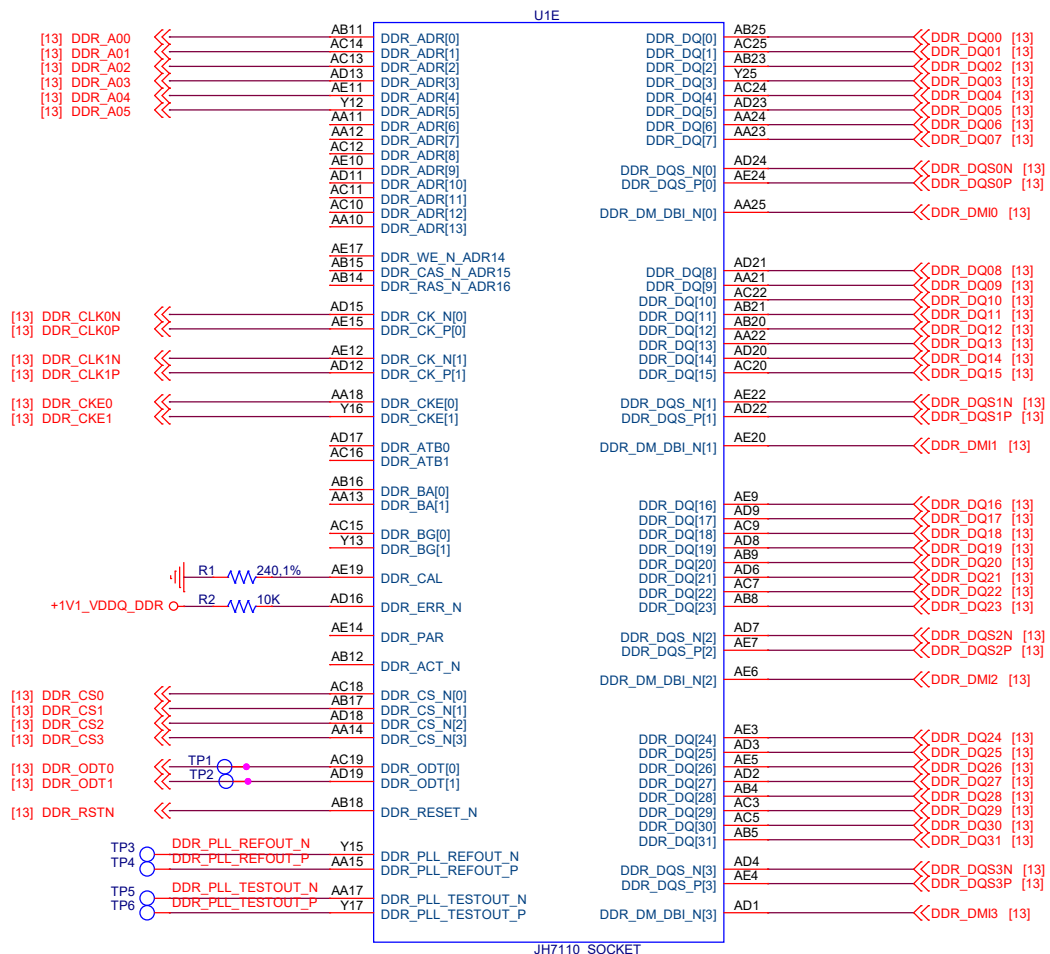

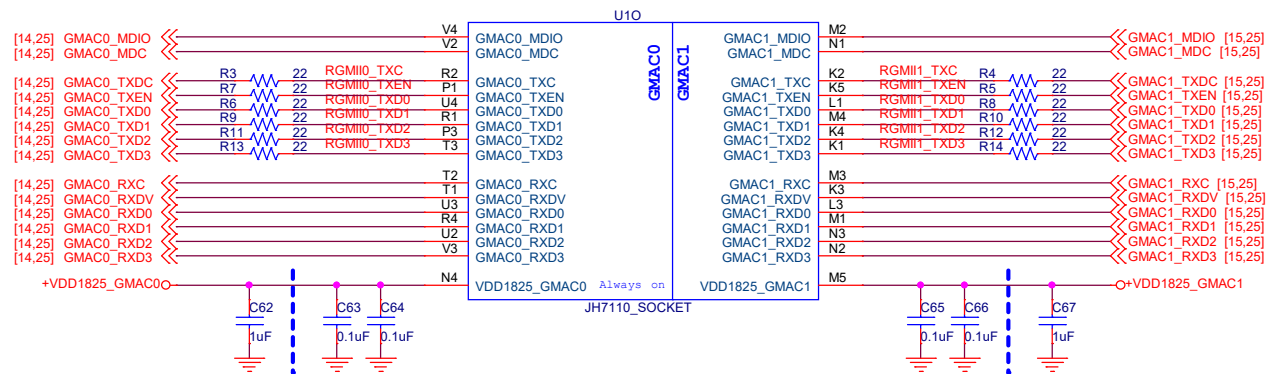

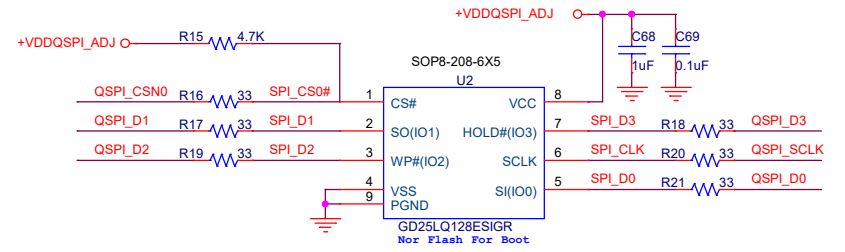
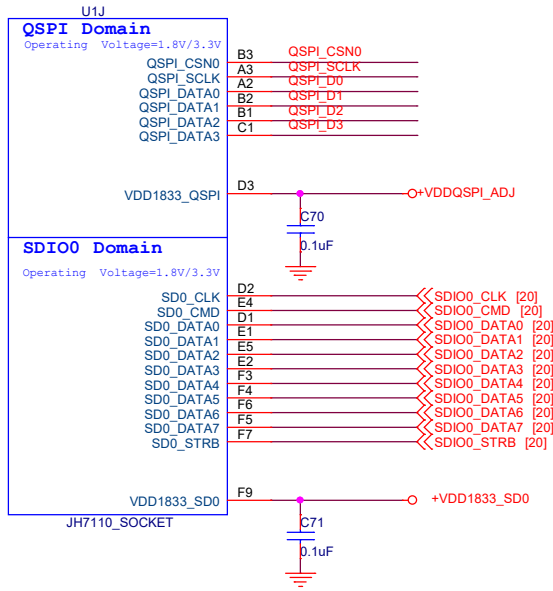

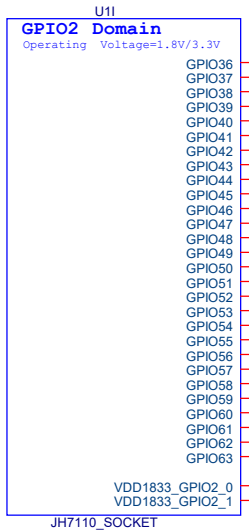
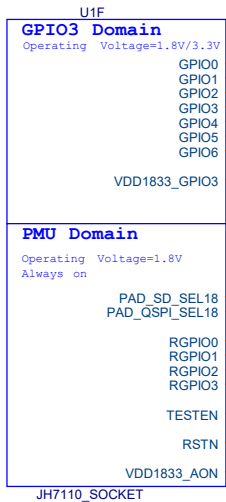

BOOT MODE

BOOT MODE (RGPI02)	Boot Vector	Boot Selection (RGPI01,0)	Note
0x1	0x00_2100_0000	XIP Flash	can not boot from XIP Flash, if disabled thru OTP Configuration.
0x0	0x00_2A00_0000	0x0: 1Bit QSPI Nor Flash 0x1: SDIO3.0 0x2: eMMC5.0 0x3: UART	on-chip boot ROM(32KB)

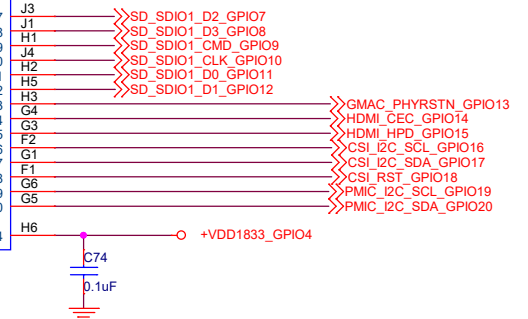
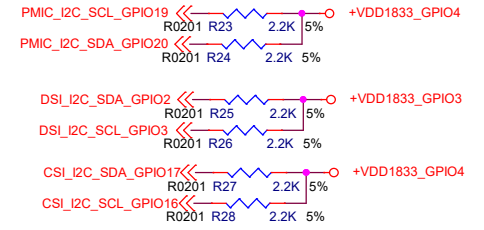
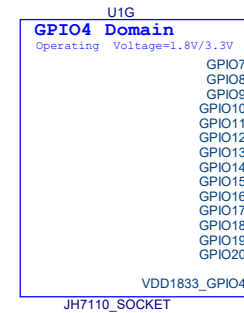
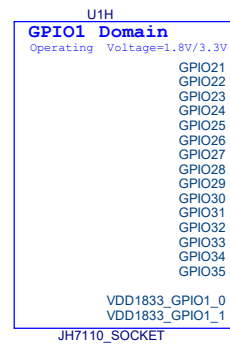
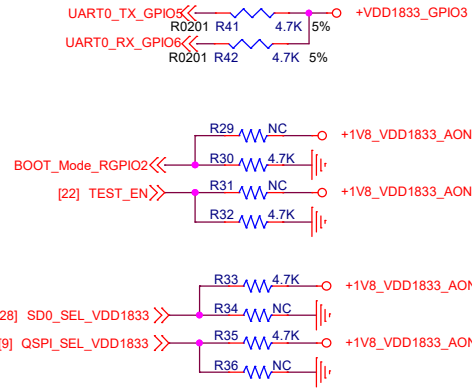

GPIO 1	GPIO 0	
0	0	Flash
0	1	SD
1	0	eMMC
1	1	UART

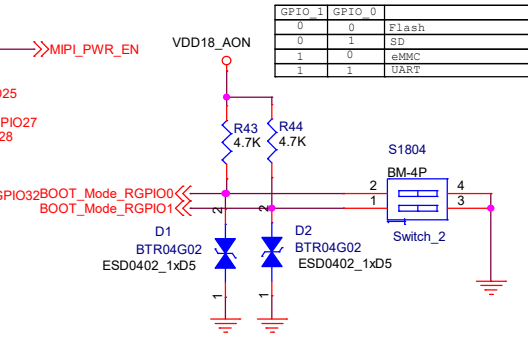

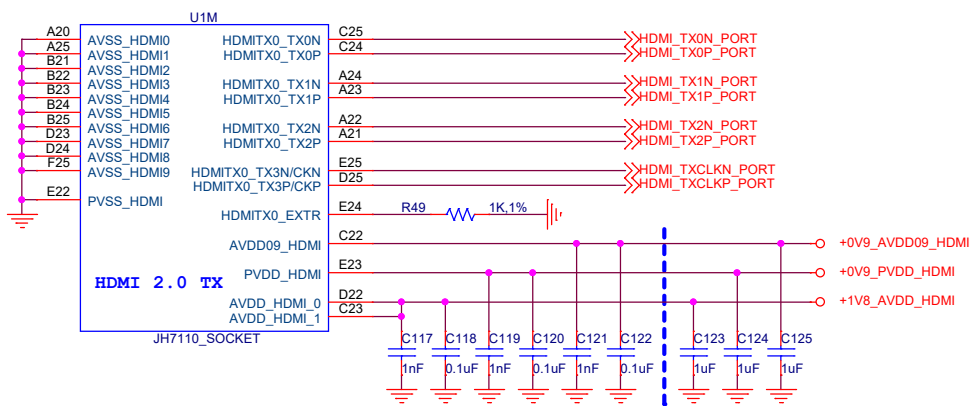
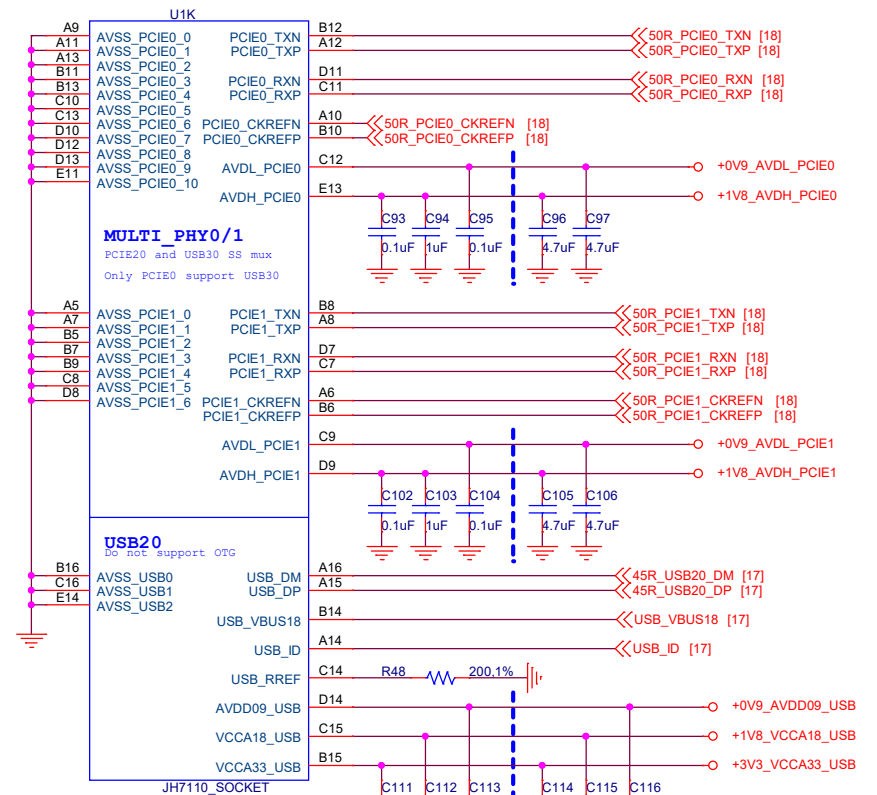
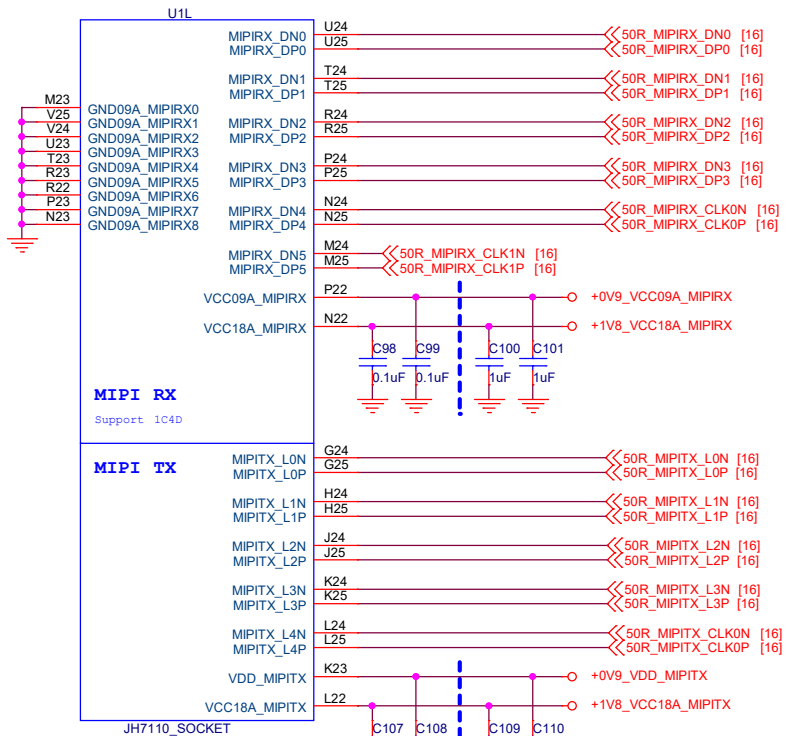

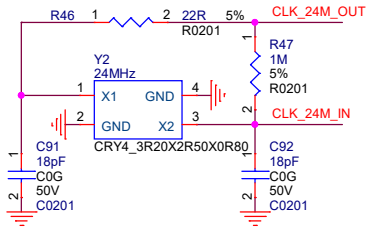
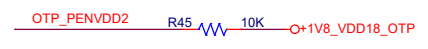
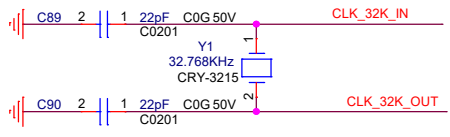
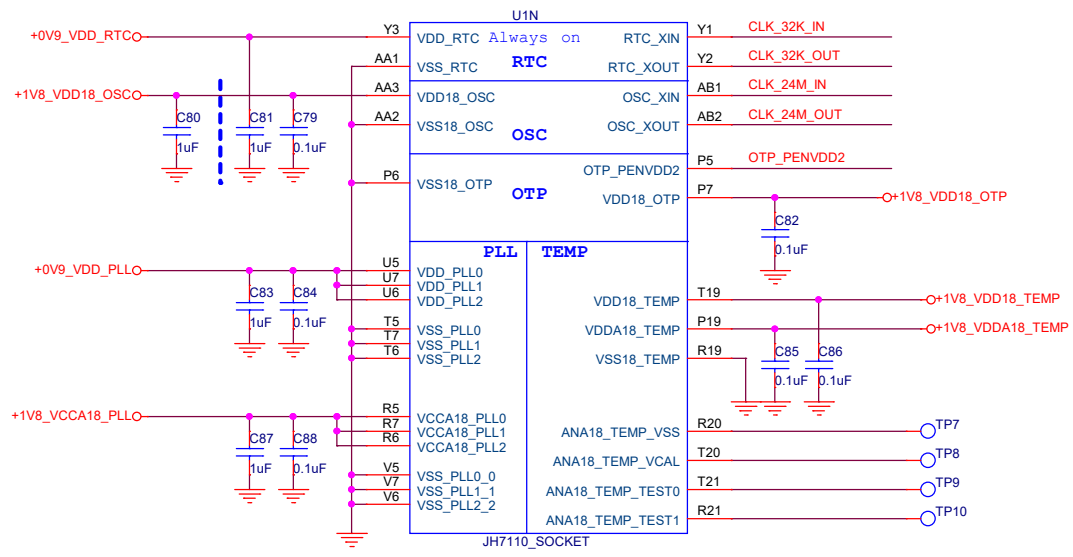

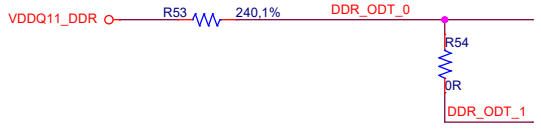
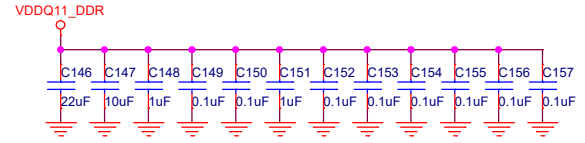
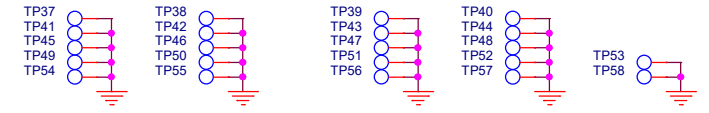
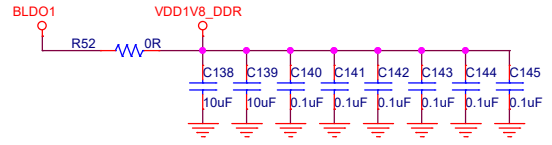
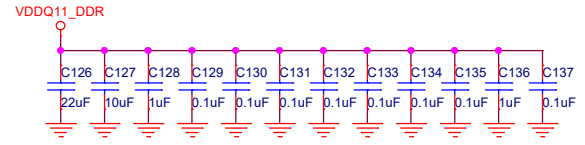
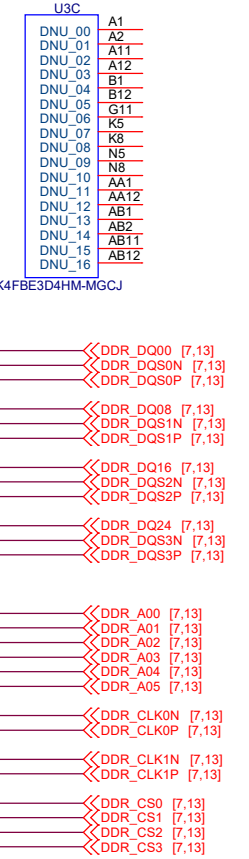
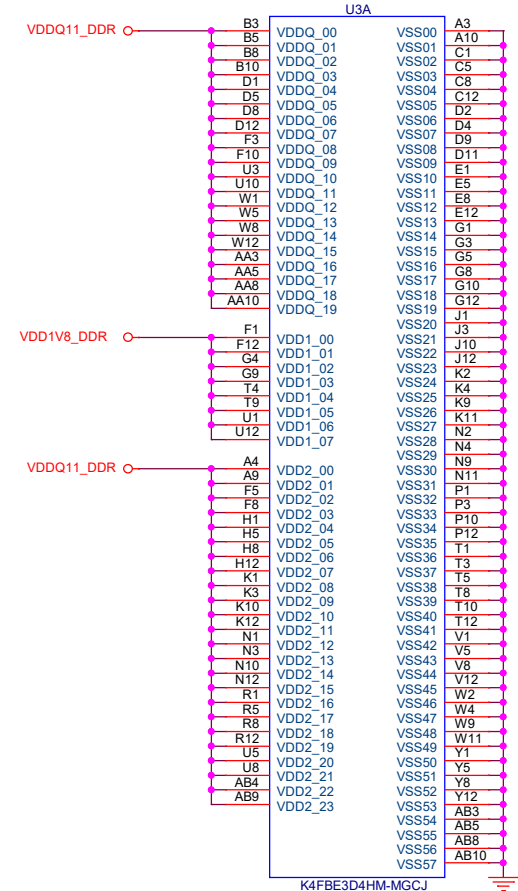
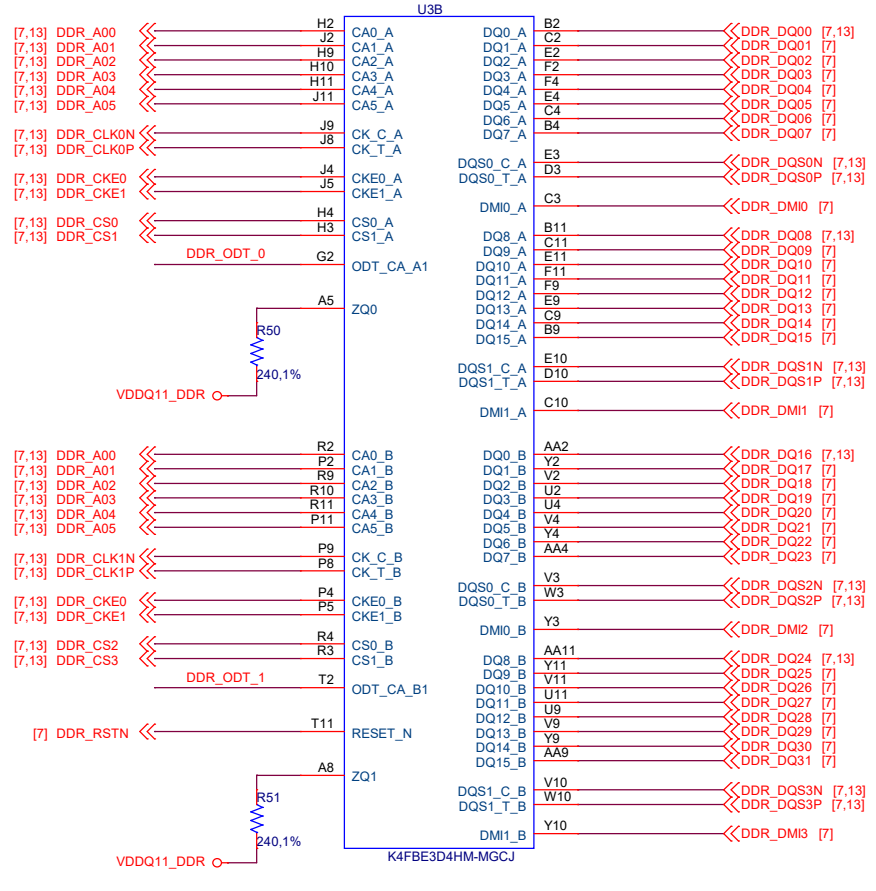

Giga PHY0

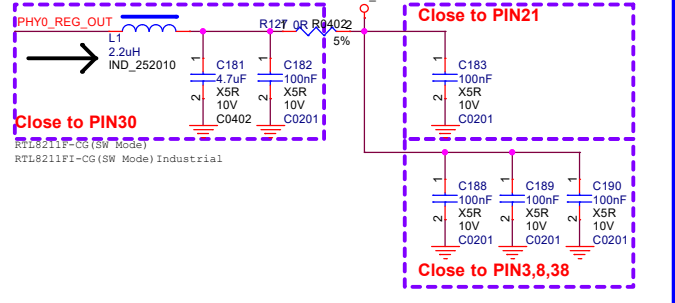
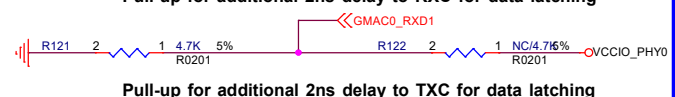
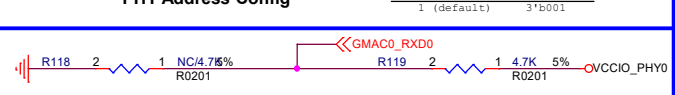
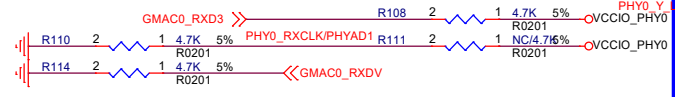
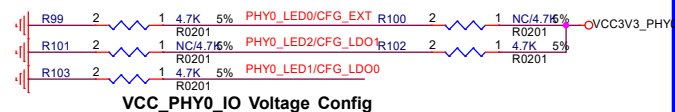
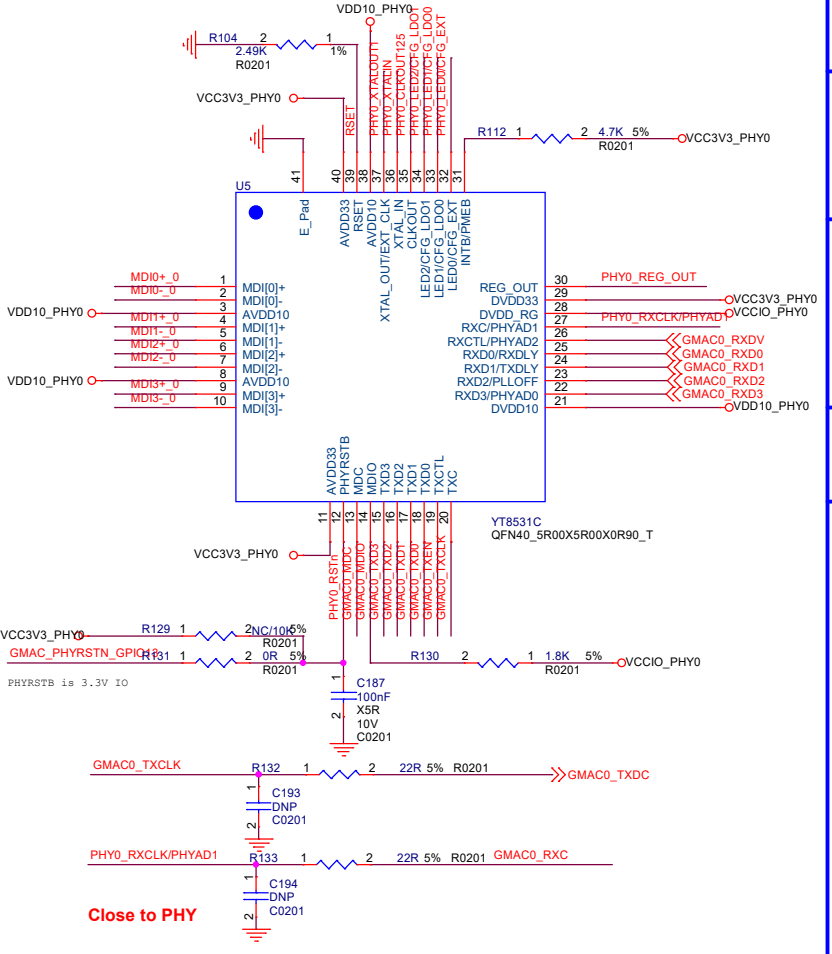
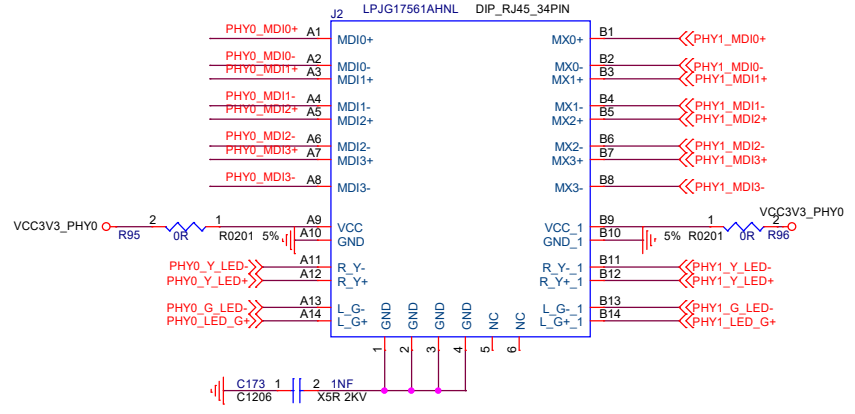
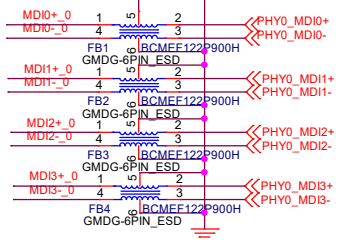
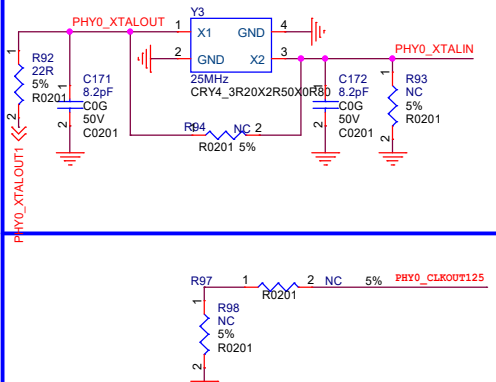
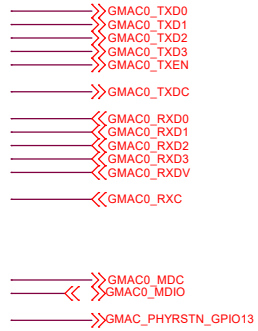

RGMI1 Power Source	CFG EXT	CFG LDO[1:0]
External 3.3V	1'b1	2'b00
External 1.8V	1'b1	2'b10
Internal 1.8V(default)	1'b0	2'b10

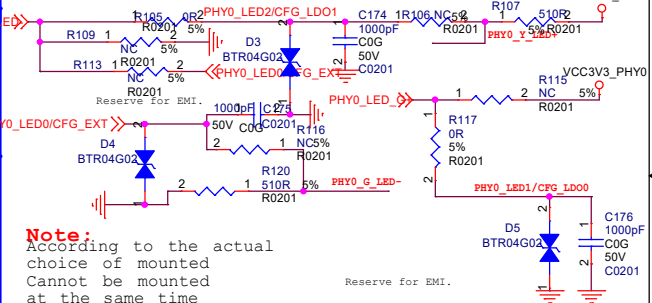

Giga PHY1

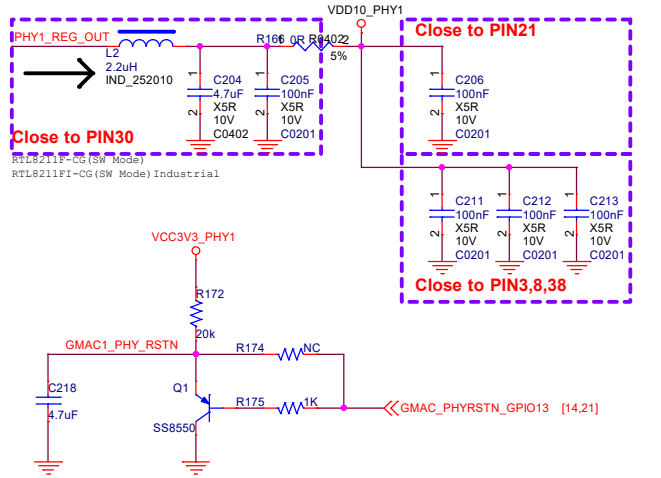
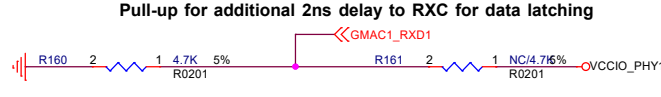
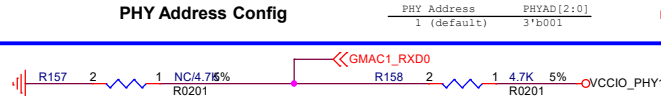
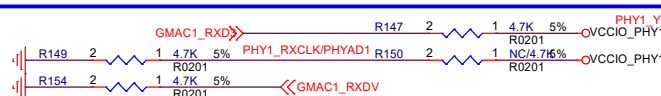
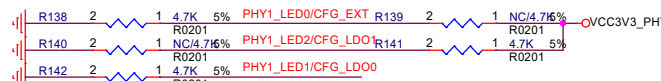
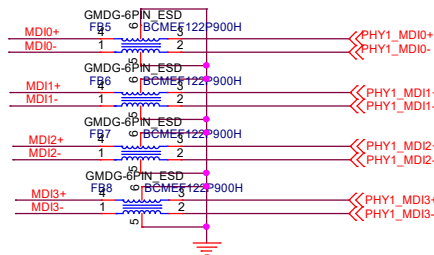
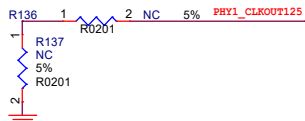
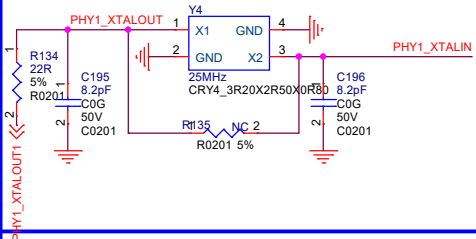
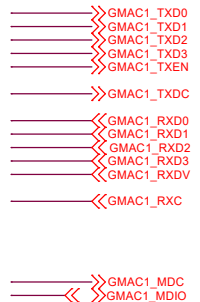

RGMI Power Source	CFG_EXT	CFG_LDO[1:0]
External 3.3V	1'b1	2'b00
External 1.8V	1'b1	2'b10
Internal 1.8V(default)	1'b0	2'b10

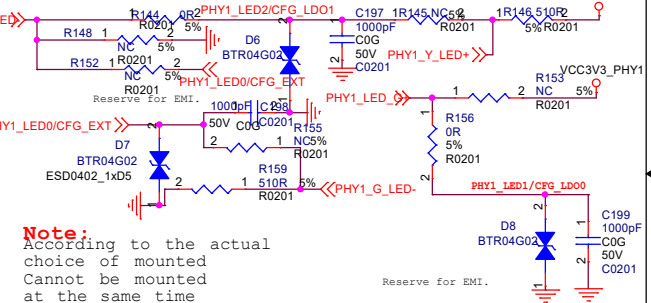

Note: According to the actual choice of mounted cannot be mounted at the same time

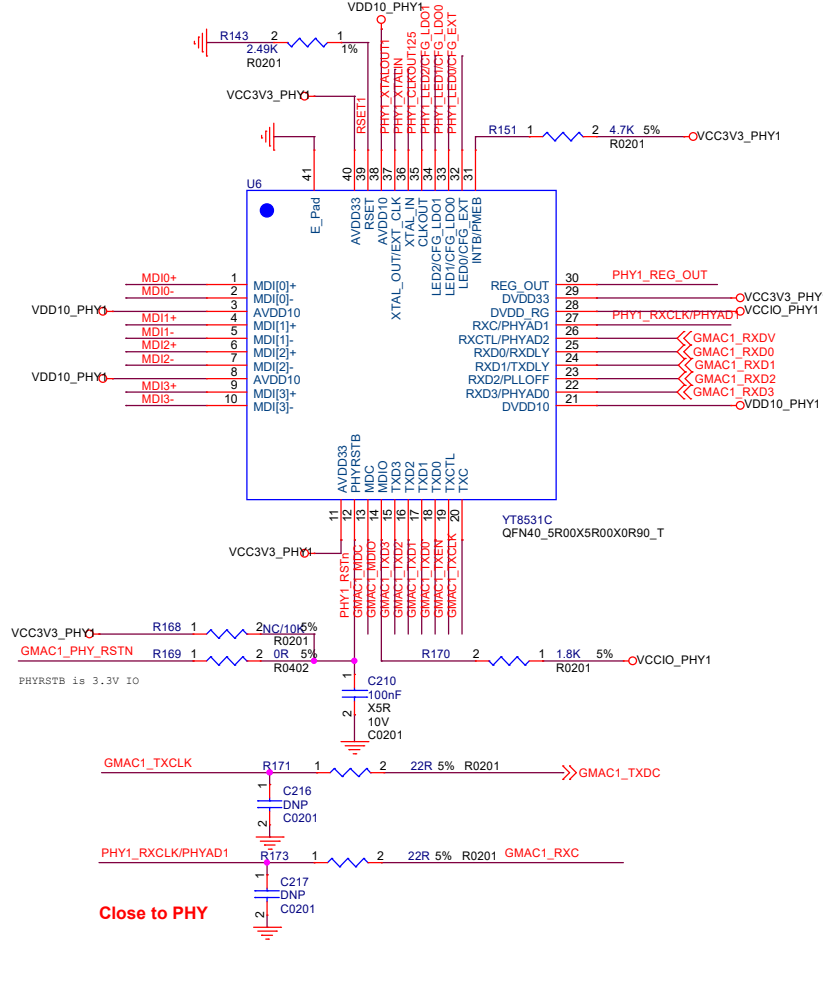

MIPI_RX0

[10,26] GPIO51 << 0R R75 R0201 >> CSI_PDN_GPIO51

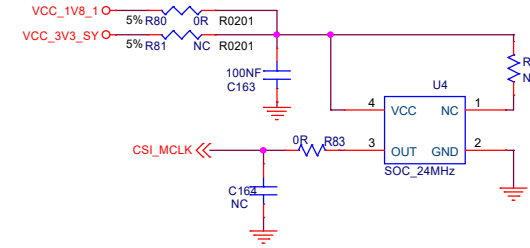
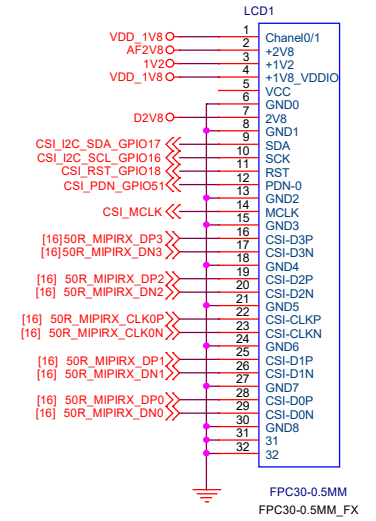
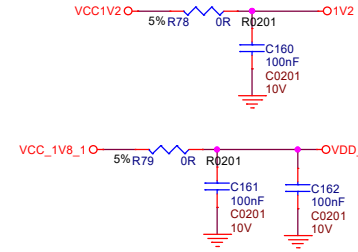
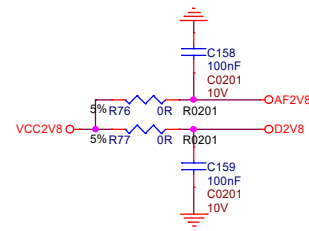
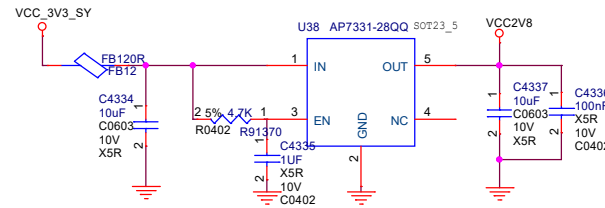
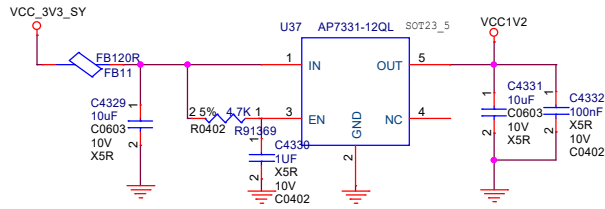

AUDIO

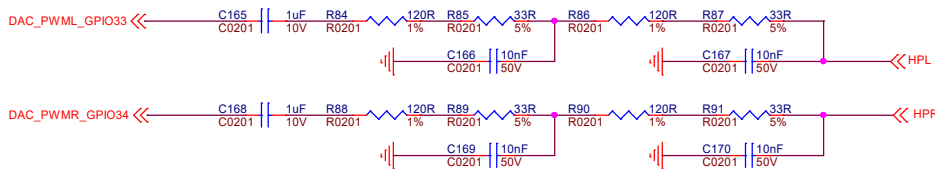
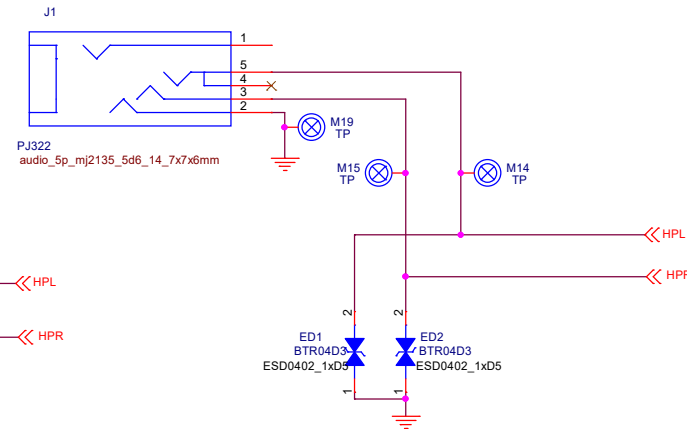

MIPI_LCD_TX1

LCD_TP

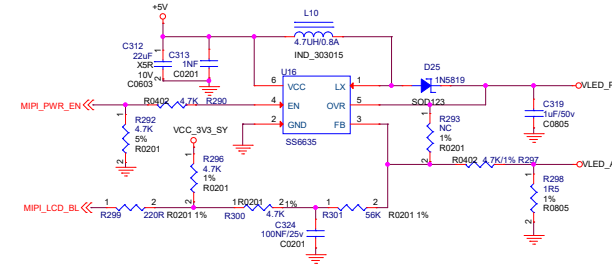
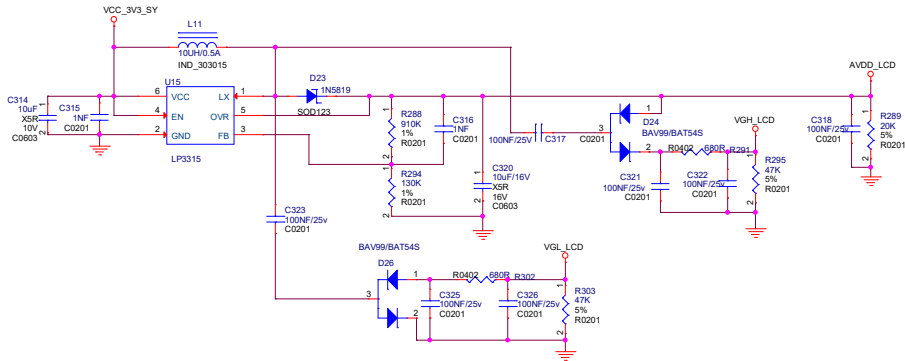
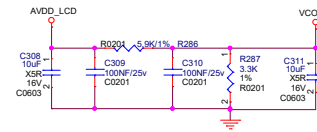
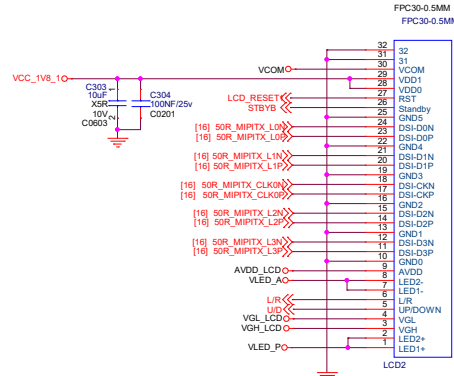
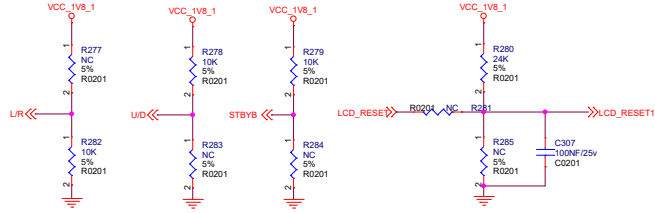
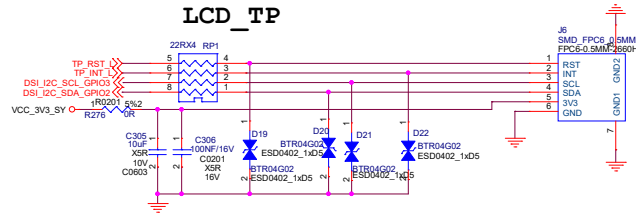

Digital Video

- >>> HDMI_TX2P_PORT
- >>> HDMI_TX2N_PORT
- >>> HDMI_TX1P_PORT
- >>> HDMI_TX1N_PORT
- >>> HDMI_TX0P_PORT
- >>> HDMI_TX0N_PORT
- >>> HDMI_TXCLKP_PORT
- >>> HDMI_TXCLKN_PORT
- >>> HDMI_I2C_SCL_GPIO0
- >>> HDMI_I2C_SDA_GPIO1
- >>> HDMI_CEC_GPIO14
- >>> HDMI_HPD_GPIO15

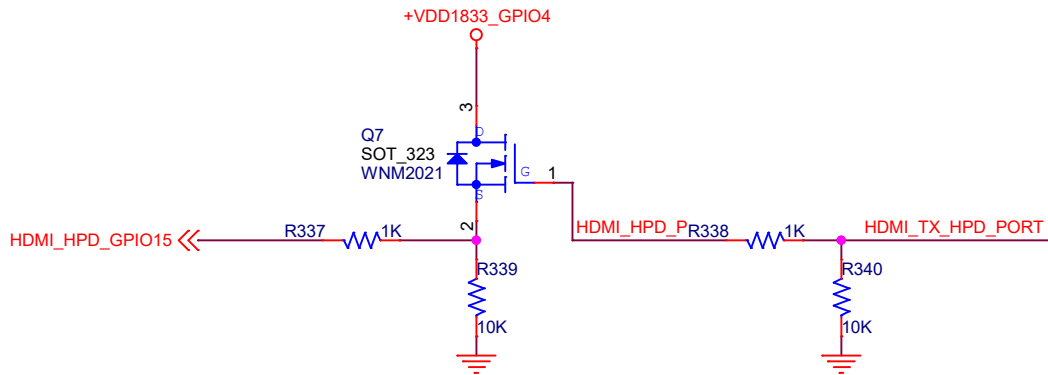
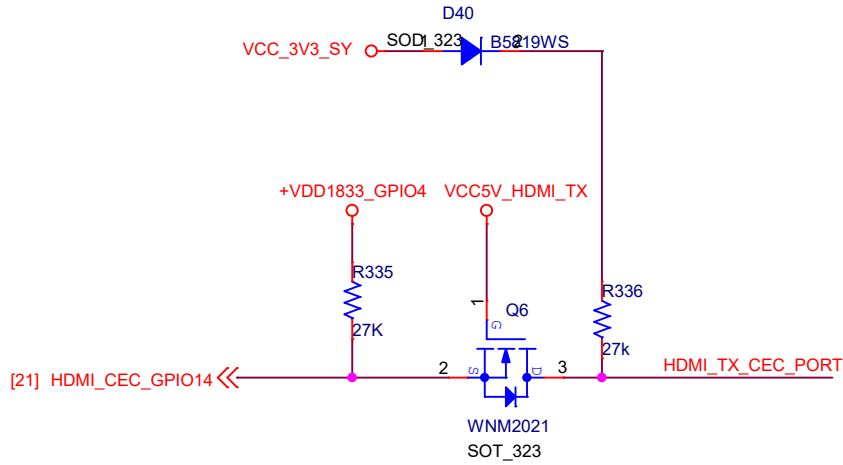
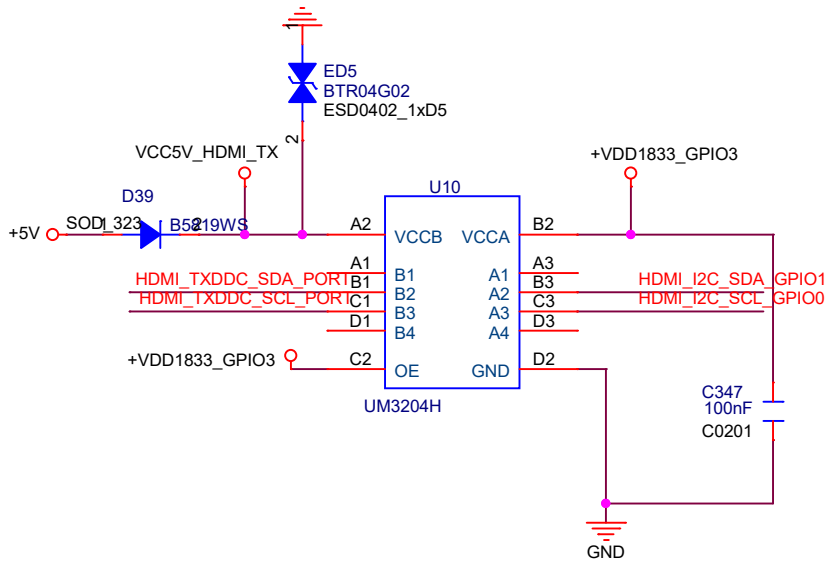

$$C_j \leq 0.4 \text{ pF}$$

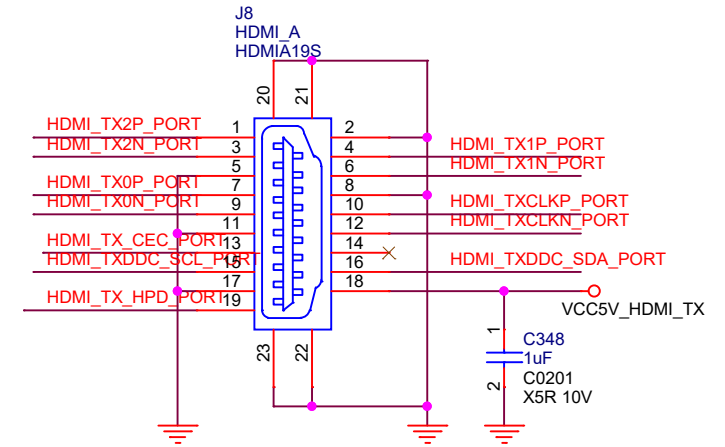
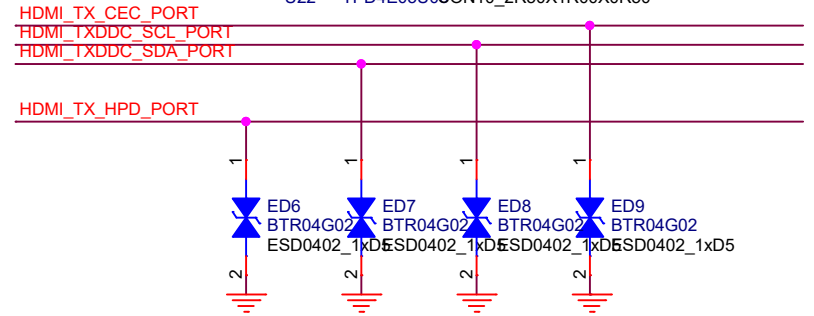
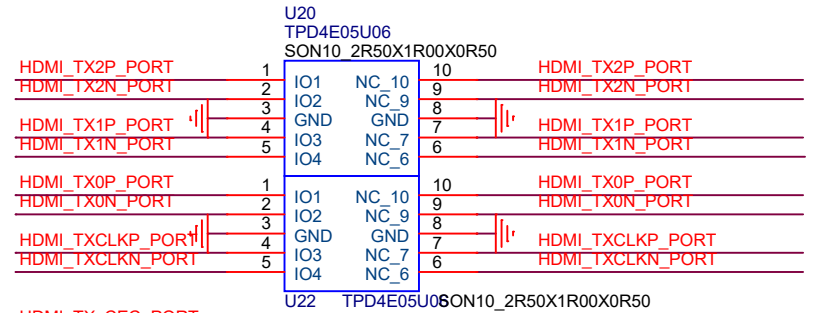

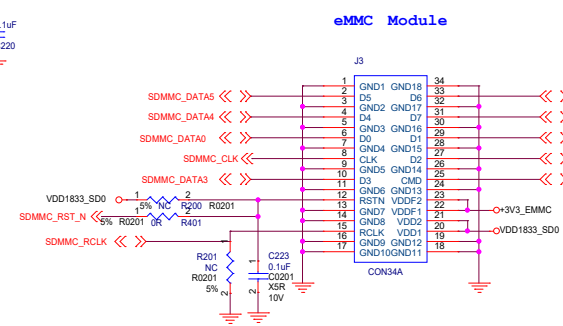
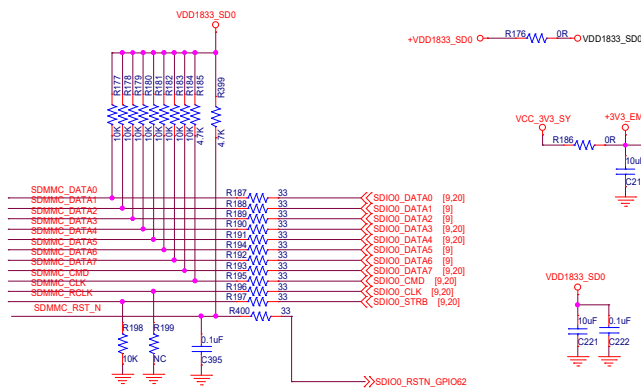

Micro SD Card

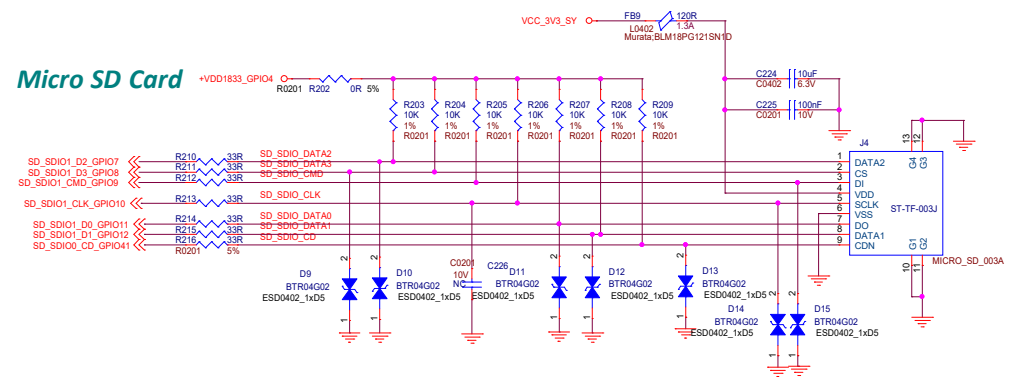

Power

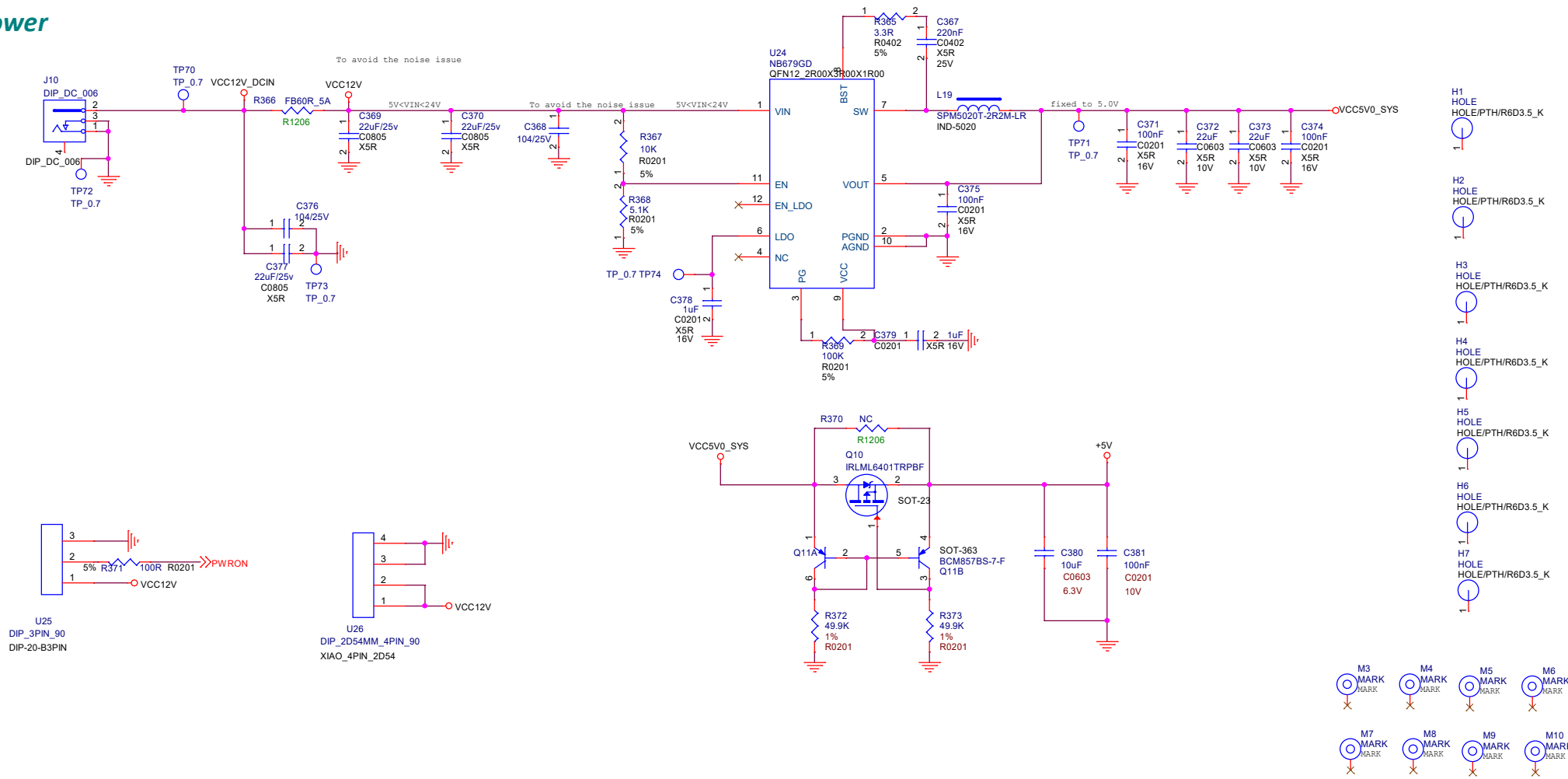

PMU

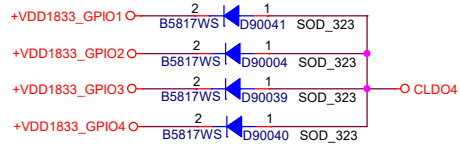
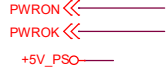

ACK&Power LEDs

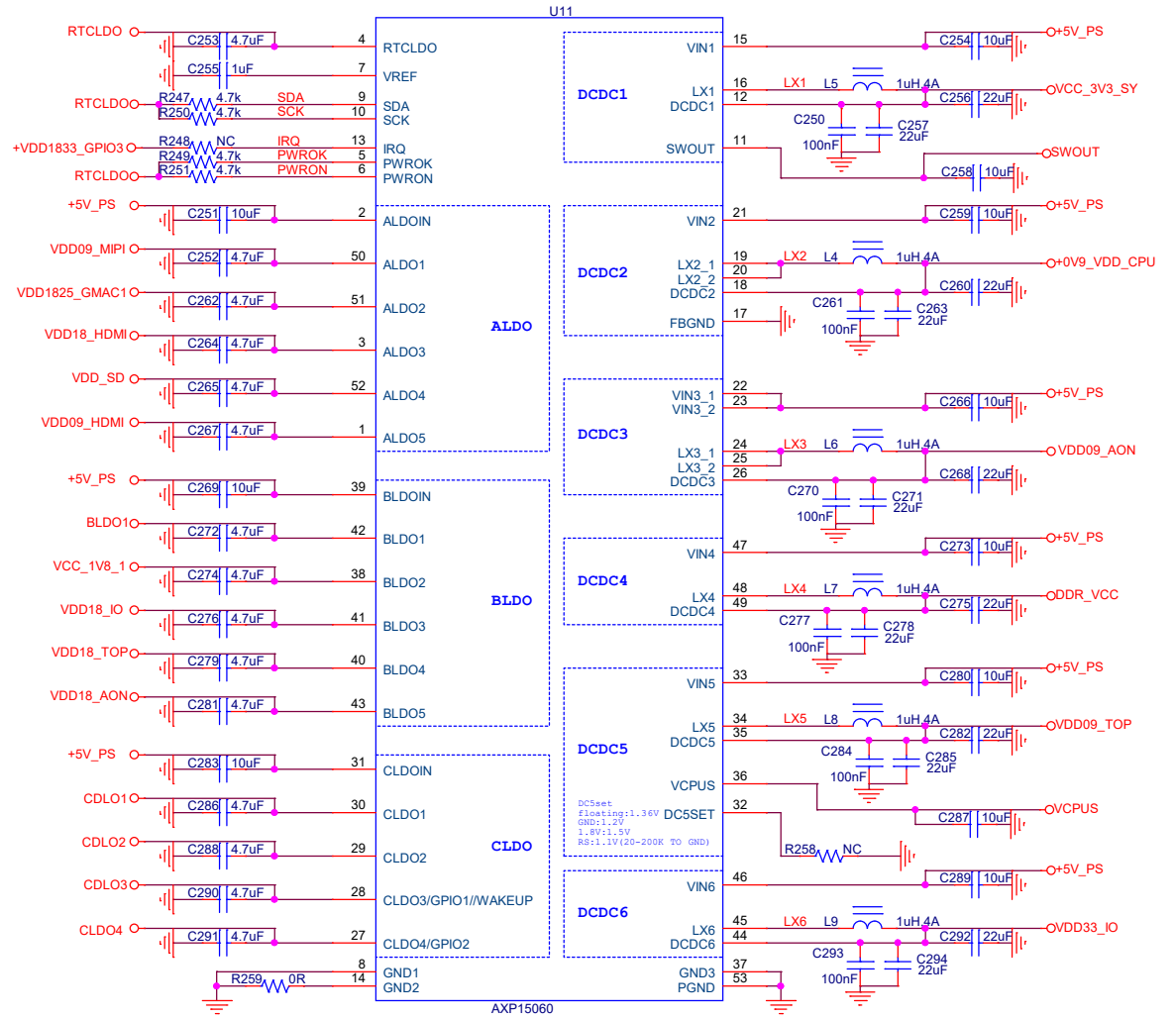
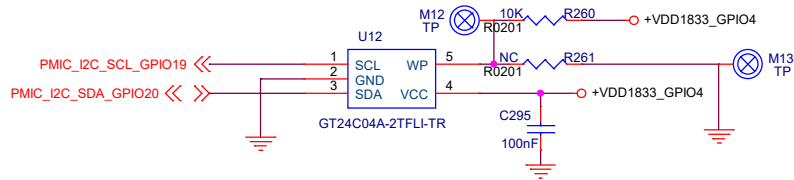
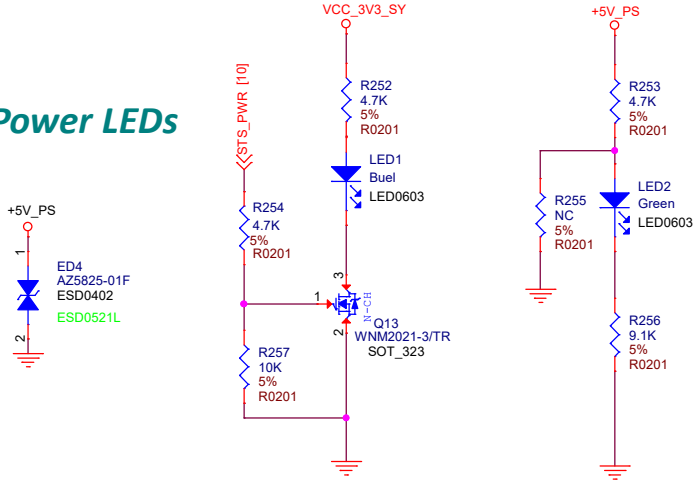

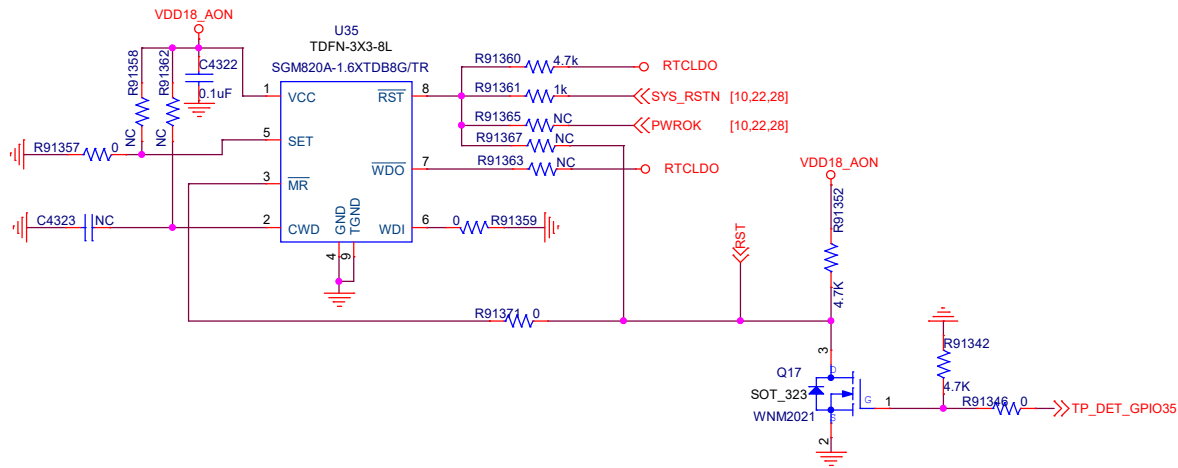
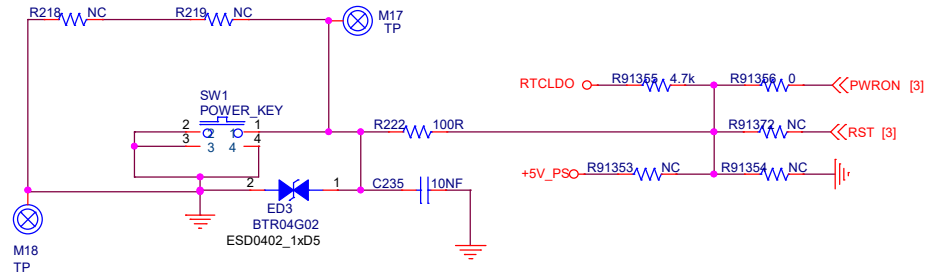
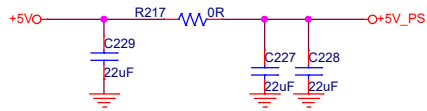

Timing 1

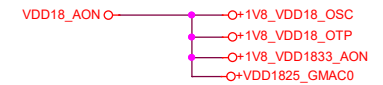

Timing 2

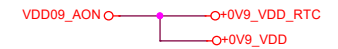

Timing 3

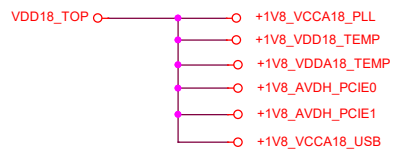
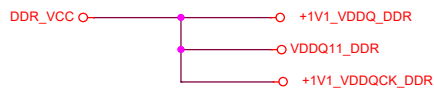
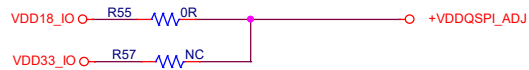

Timing 3

Timing 4

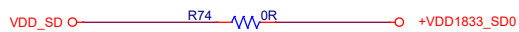
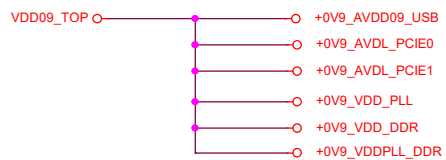

Timing 5



Timing 6

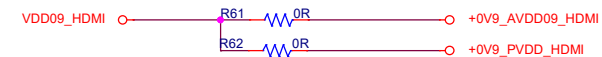

Timing 7

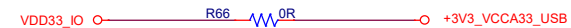

USB Hub0

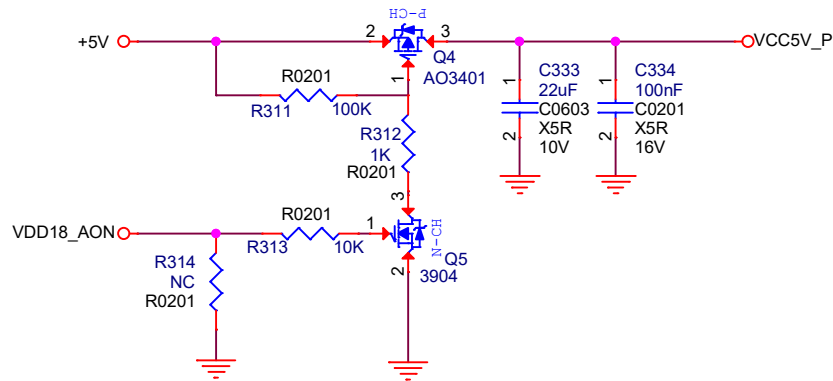
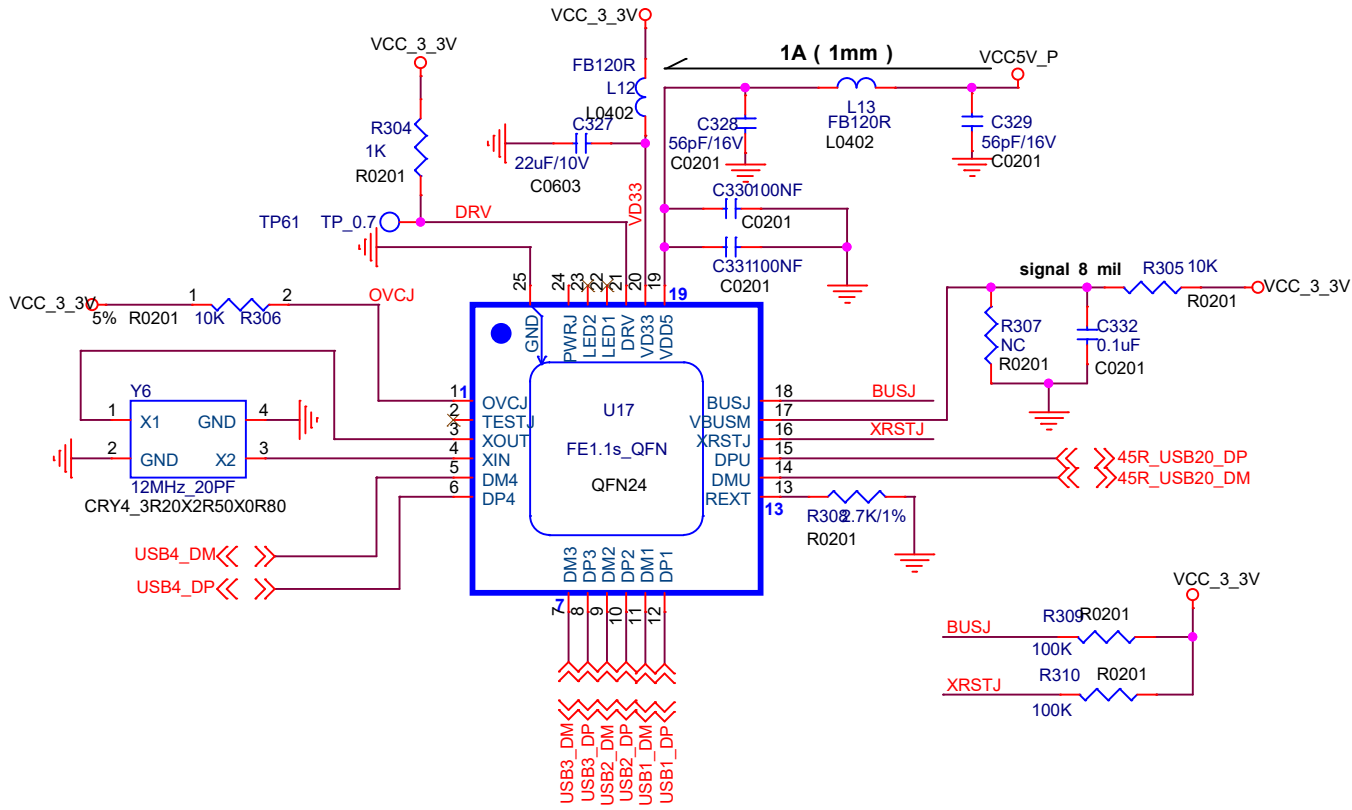

USB Hub1

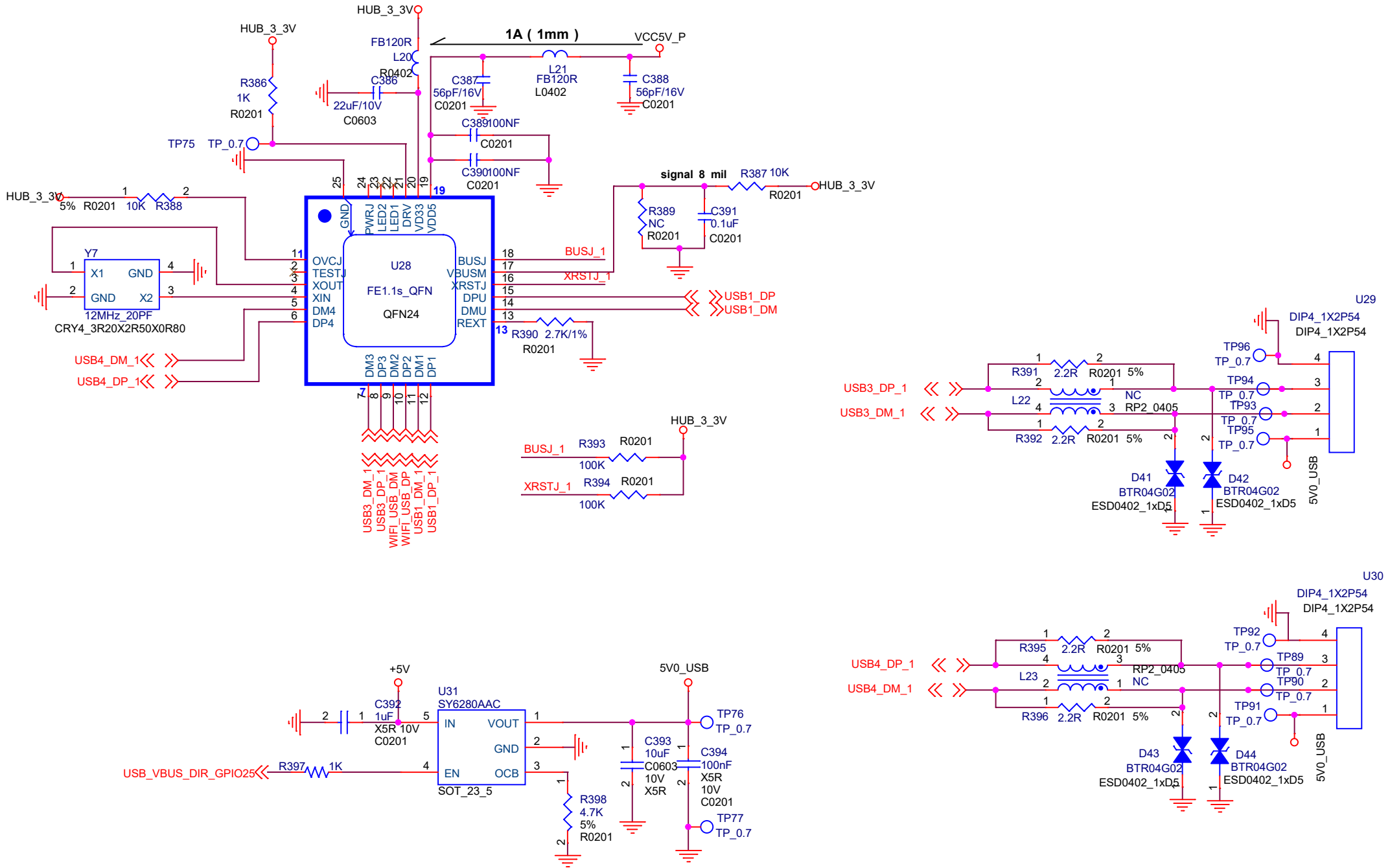

USB Ports

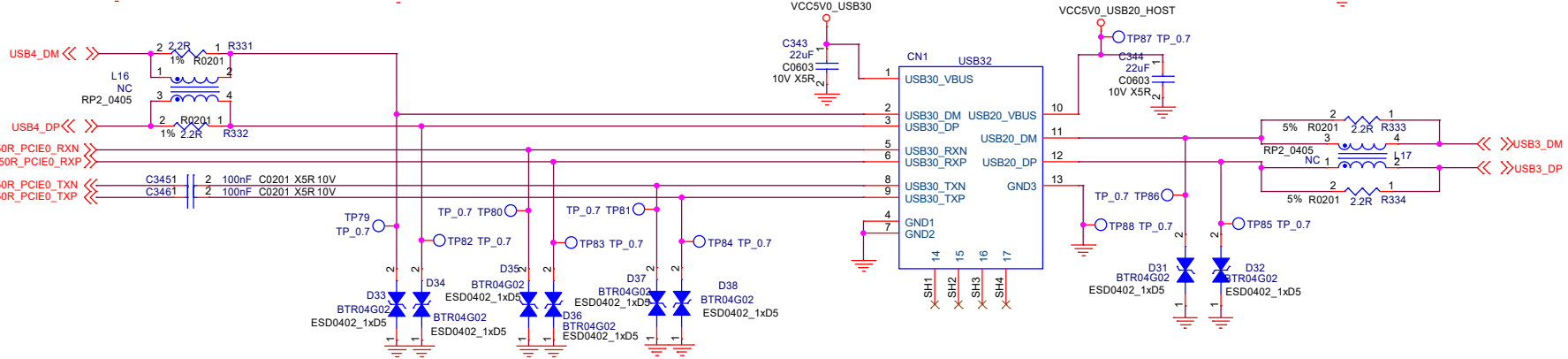
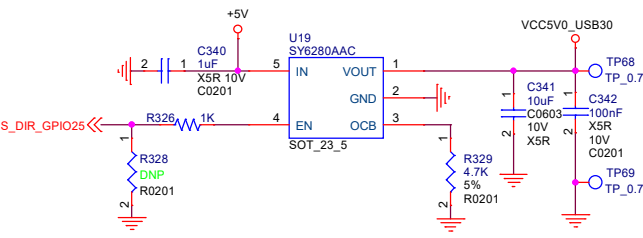
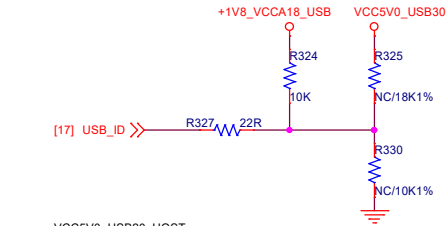
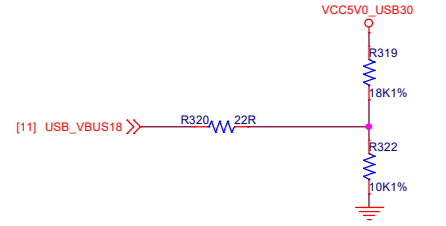
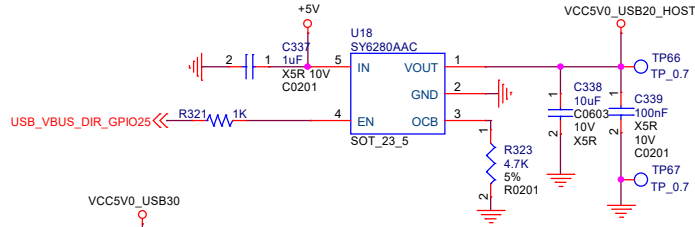
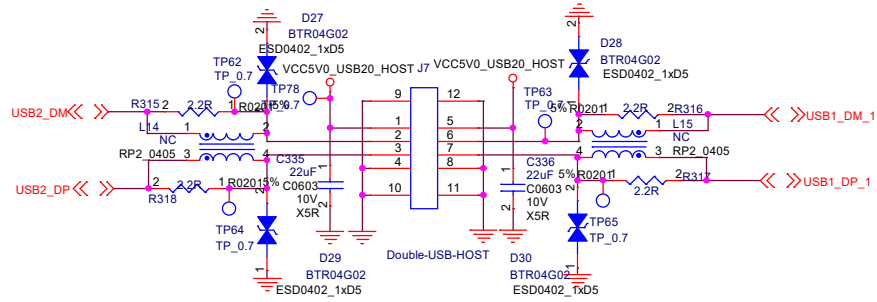

USB WIFI Module

