

Version	Date	Author	Change Note	Approved
V21	20180708	XieXiaoMin	见附件：PinebookPro_V21项目修改评审记录.docx 充电电流参数更改，PD充电电路优化 键盘控制IO加密功能修改：初始化为高阻，启用时为低电平 <ol style="list-style-type: none"> <li>1.增加Q15，R151 实现高电平通，低电平断。控制麦克风的电源</li> <li>2.增加D13.实现高电平不干扰WIFI功能，低电平使WIFI无法打开</li> <li>3.增加D14.实现高电平不干扰USB摄像头的工作，低电平使摄像头的电源打不开</li> </ol> 增加U7005 EEPROM 保存键盘状态 增加工作状态灯IO使能控制，Standby LED: GPIO0_A2, Work LED: GPIO0_B3 LCD电源增加MOS管控制，控制IO口为GPIO1_C6，初始化状态为高，休眠时拉低	WenXue
V21	20181107	XieXiaoMin	低电闪屏现象，增加钽电容，位号CP1，规格TAJB226K020RNJ，详细见18页 针对辐射认证，摄像头USB差分信号兼容共模电感，位号FB3，规格SDCW2012-2-900TF	
V21	20211207	XieXiaoMin	由LPDDR4-366球更改为LPDDR4-200球           13页 USB HUB芯片由SSOP28更改为QFN28封装       22页 EMMC进MASKROM由7脚波动开关更改为2脚拨码开关   14页	

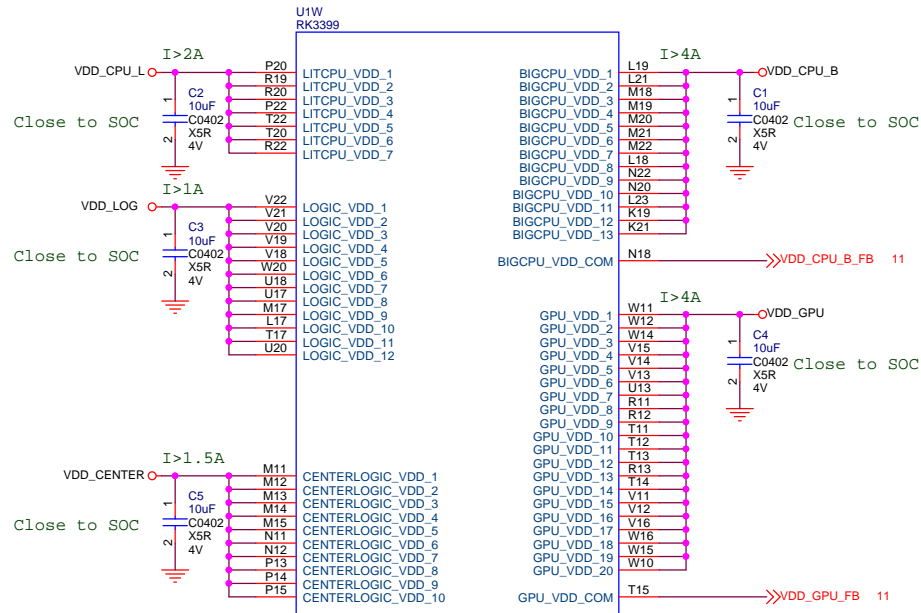

Note: Power filter CAP please place back of SOC or close to SOC

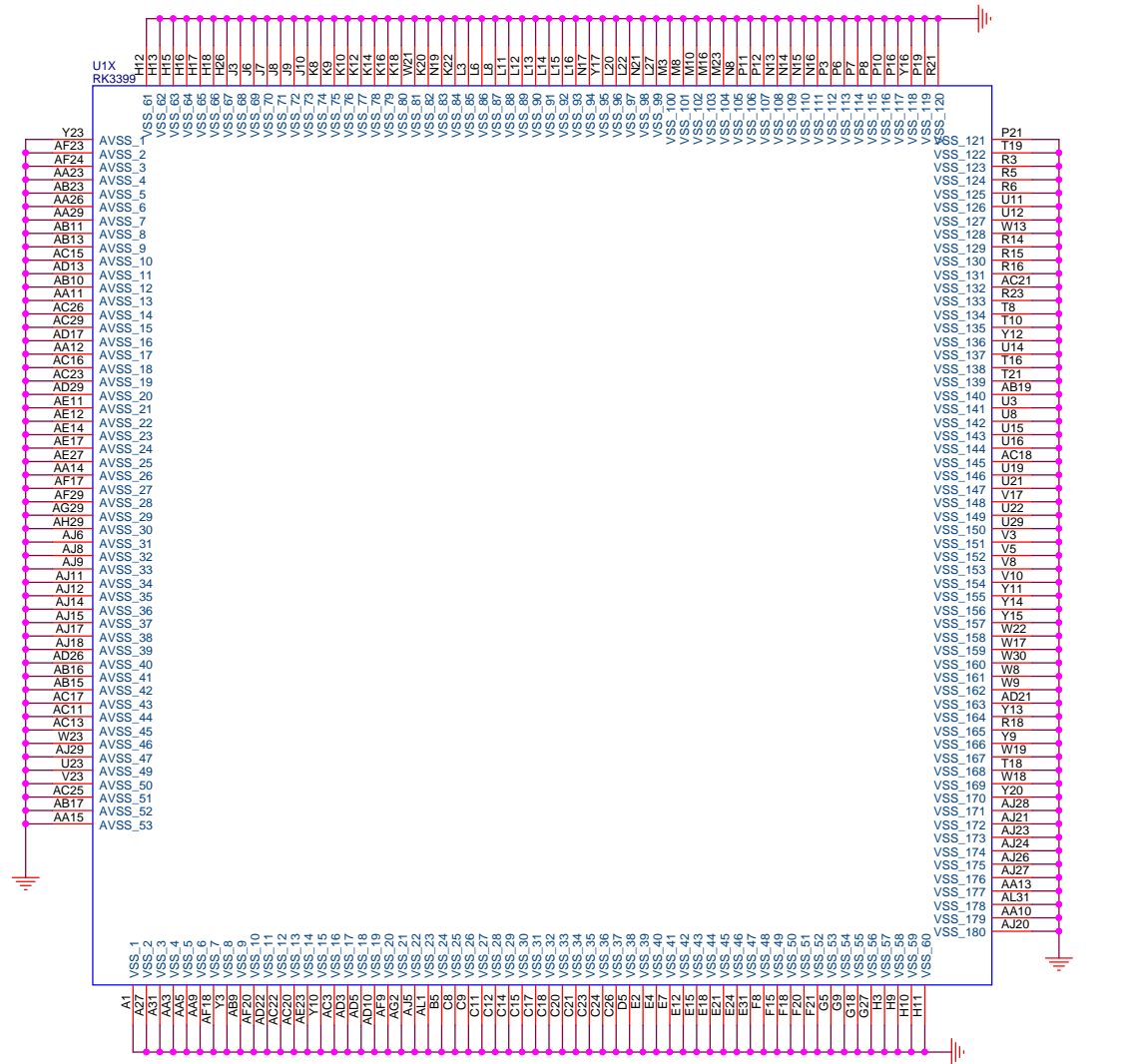
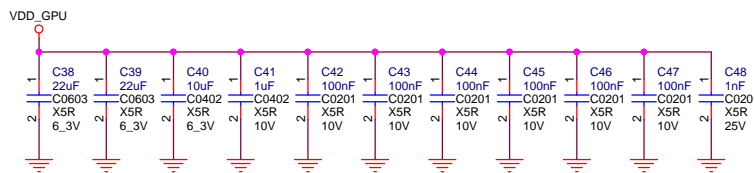
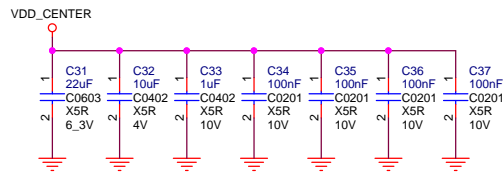
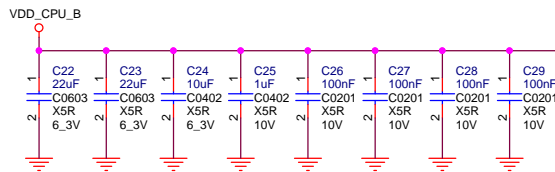
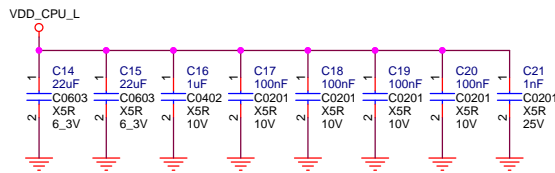
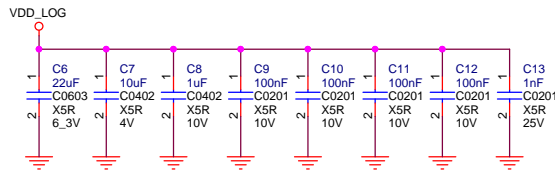

PINE64		<b>PINE64</b>	
Title	Pinebook Pro		
Size	Document Number		
A3	RK3399 POWER		Rev
Date:	Sheet 1 of 23		V2.1

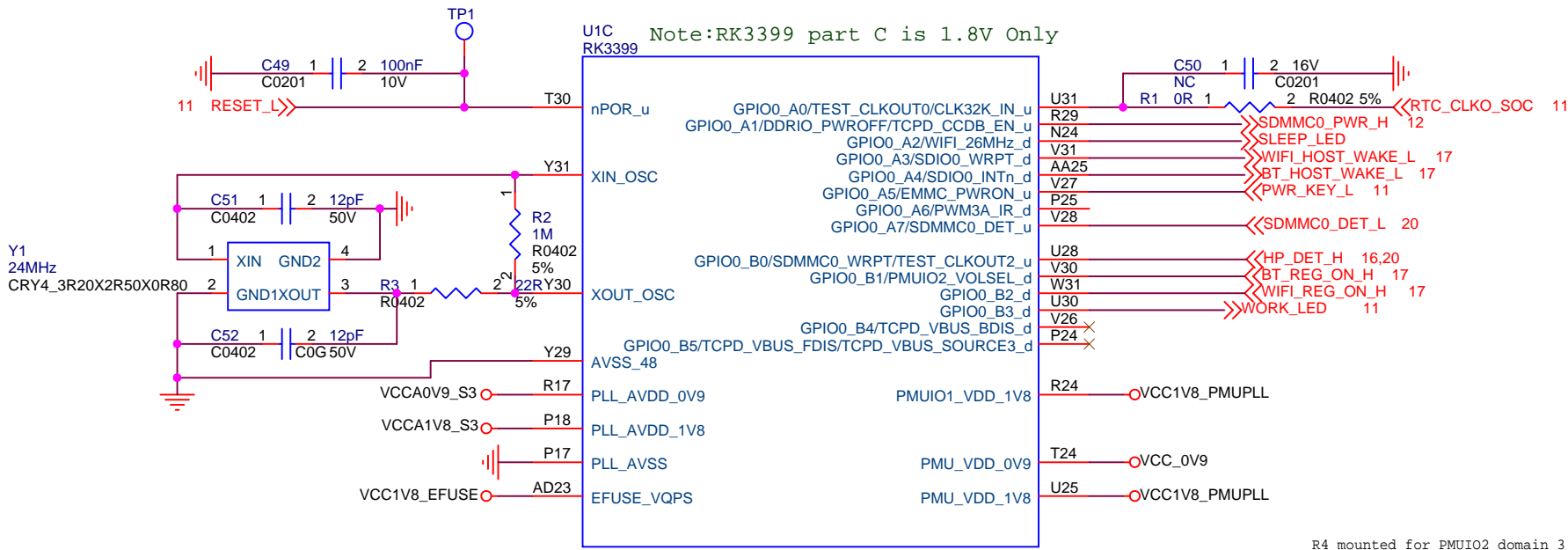

R4 mounted for PMUIO2 domain 3.0V mode

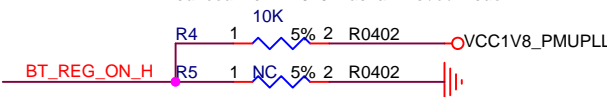

VCC1V8\_EFUSE

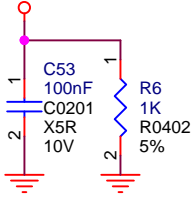

VCCA0V9\_S3

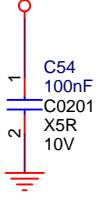

VCCA1V8\_S3

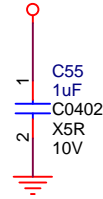

VCC1V8\_PMUPLL

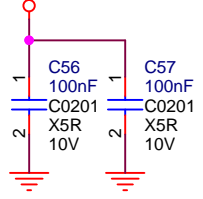

VCC\_0V9

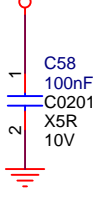

PINE64		<b>PINE64</b>	
Title Pinebook Pro			
Size A4	Document Number PMU controler		Rev V2.1
Date:	Sheet 2 of 23		

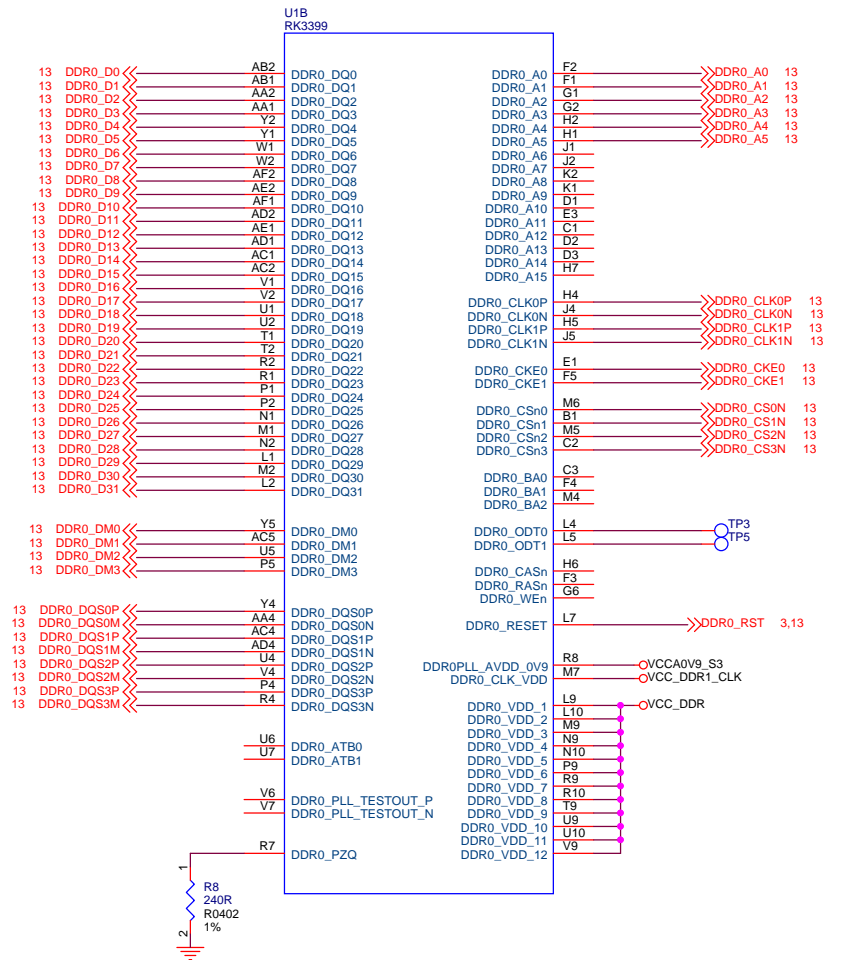
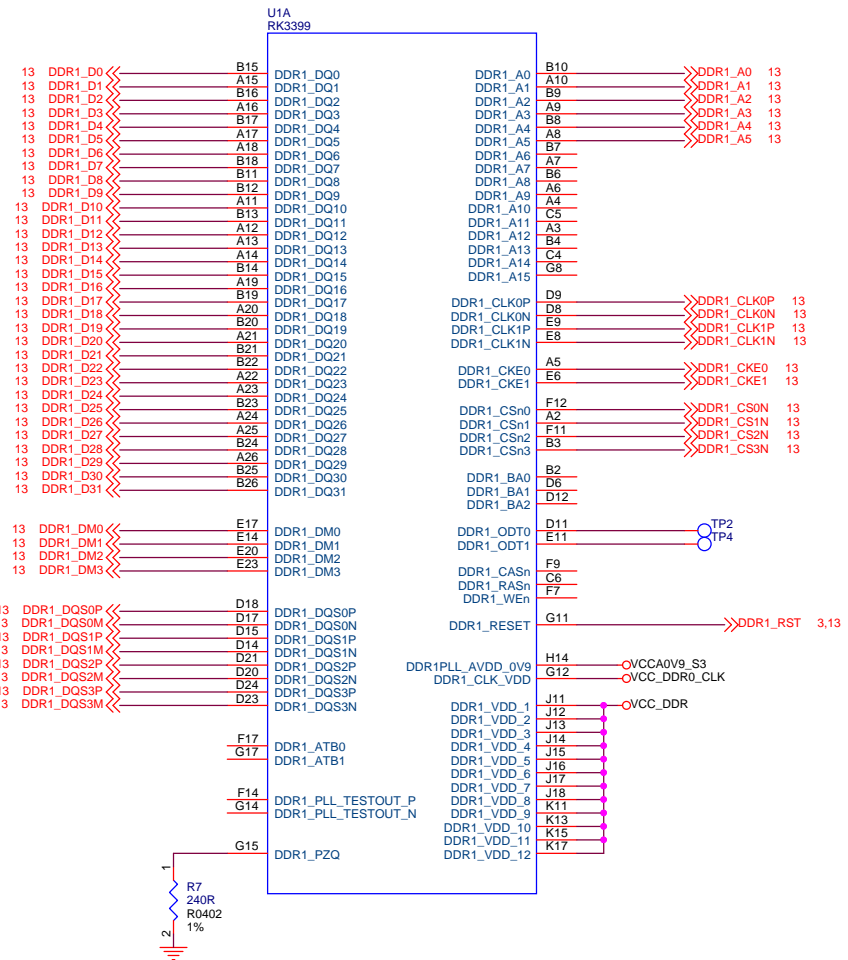

### DDR FILTER

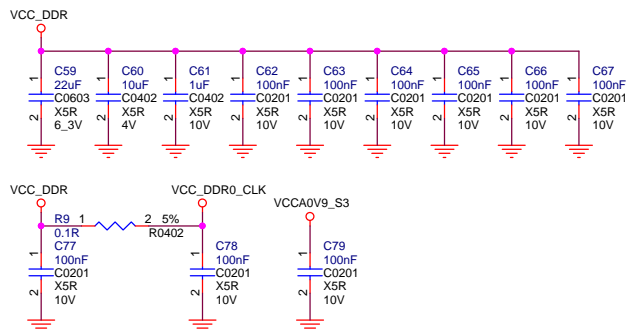

### DDR FILTER

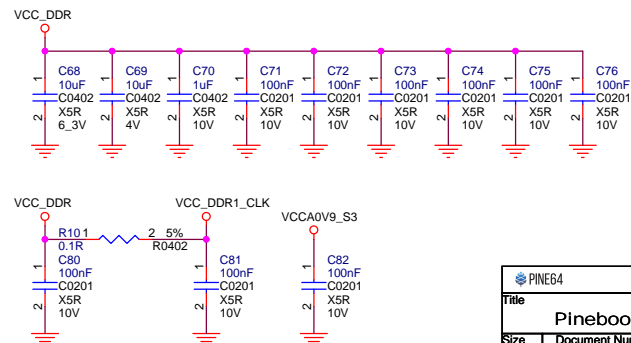

PINE64		<b>PINE64</b>	
Pinebook Pro			
Size	Document Number		Rev
A3	DDR controller		V2.1
Date:	Sheet		3 of 23

U1H  
RK3399

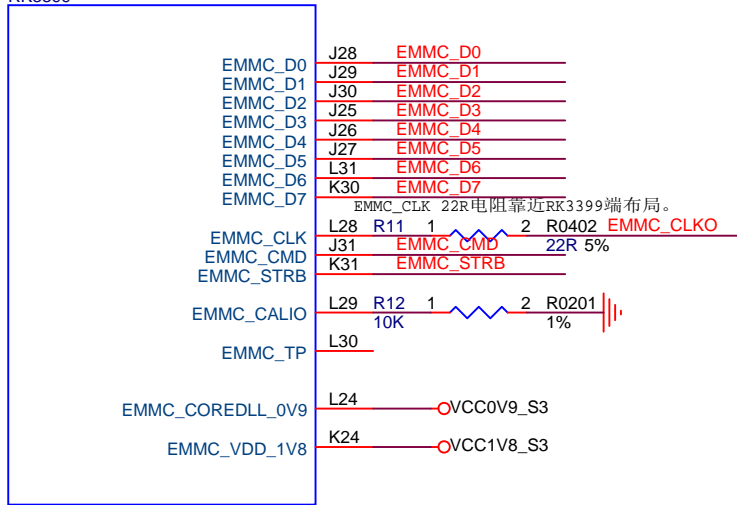

EMMC design rule:

- 1.Data[0:7]、cmd、strobe走线做为的一组，并行走线并整组包地，组内等长要求为+/-100mil;
- 2.Clk需要单独走线并包地处理，与data间的延时小于20ps;
- 3.Max trace length < 3.93 inches;
- 4.Trace impedance 50ohm+/-10%;
- 5.与其他信号间距遵循3w原则;
- 6.R1300靠近SOC放置;

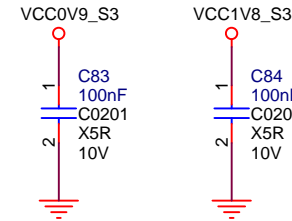
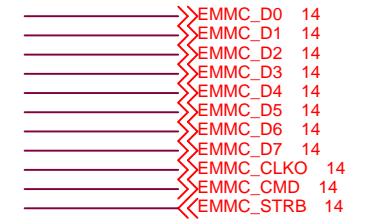

U1F  
RK3399

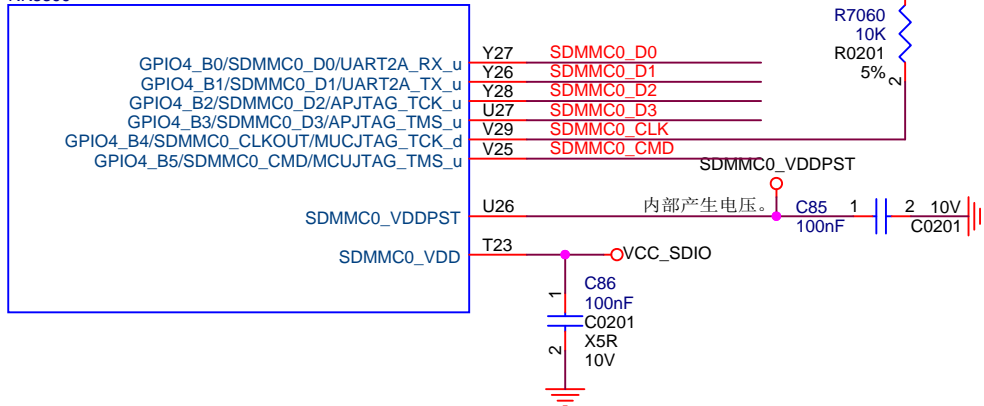

SDMMC design rule:

- 1.Data[0:3]、cmd走线做为的一组，并行走线并整组包地，组内等长要求为+/-100mil;
- 2.Clk需要单独走线并包地处理，与data间的延时小于20ps; ;
- 4.Max trace length < 3.93 inches;
- 5.Trace impedance 50ohm+/-10%;
- 6.与其他信号间距遵循3w原则;



PINE64		<b>PINE64</b>	
Title Pinebook Pro			
Size A4	Document Number FLASH&SDMMC controler	Rev V2.1	
Date:	Sheet	4	of 23

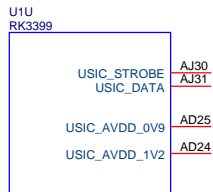

## USB2.0

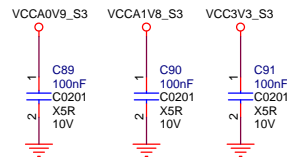
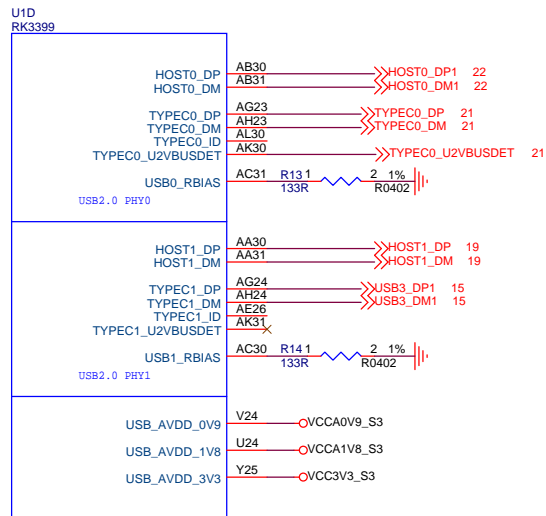

- USB2.0 design rule:
1. Max intra-pair skew < 4 ps;
  2. Max trace length < 6 inches;
  3. Max allowed via < 6;
  4. Trace impedance 90ohm+/-10%;
  5. 与其他信号间距遵循3W原则;

## USB3.0

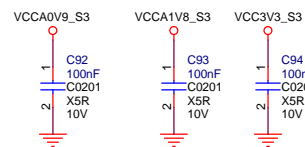
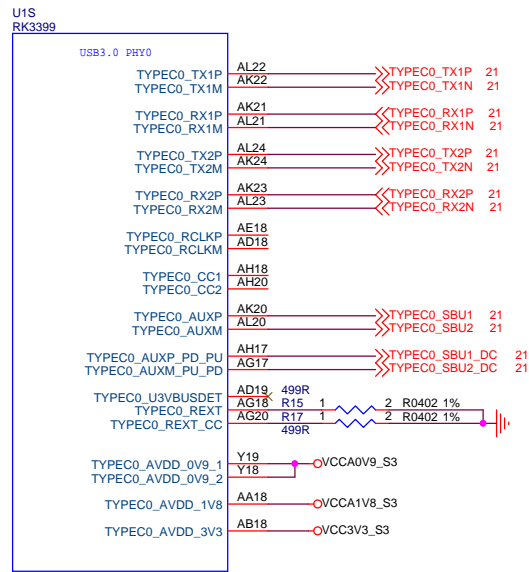

- USB3.0 design rule:
1. Max intra-pair skew < 4 ps;
  2. Max length skew between TX and RX < 1.6 ns;
  3. Max trace length < 6 inches;
  4. Max allowed via < 4;
  5. Trace impedance 90ohm+/-10%;
  6. 与其他信号间距遵循3W原则;

- DP design rule:
1. Max intra-pair skew < 4 ps;
  2. Max trace length < 6 inches;
  3. Max allowed via < 4;
  4. Trace impedance 90ohm+/-10%;
  5. 与其他信号间距遵循3W原则;

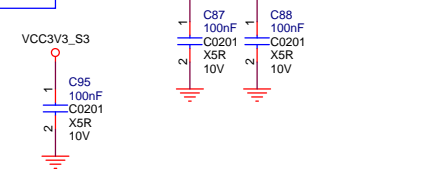
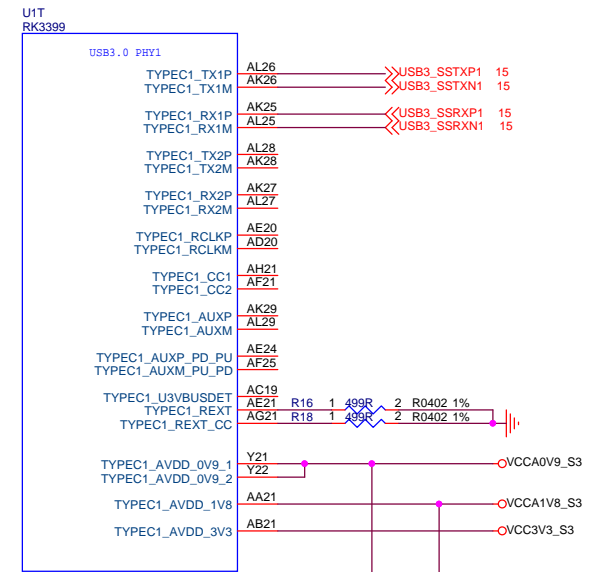

PINE64		<b>PINE64</b>	
Pinebook Pro			
Title	Document Number		Rev
A3	USB CONTROLLER		V2.1
Date:	Sheet 5 of 23		

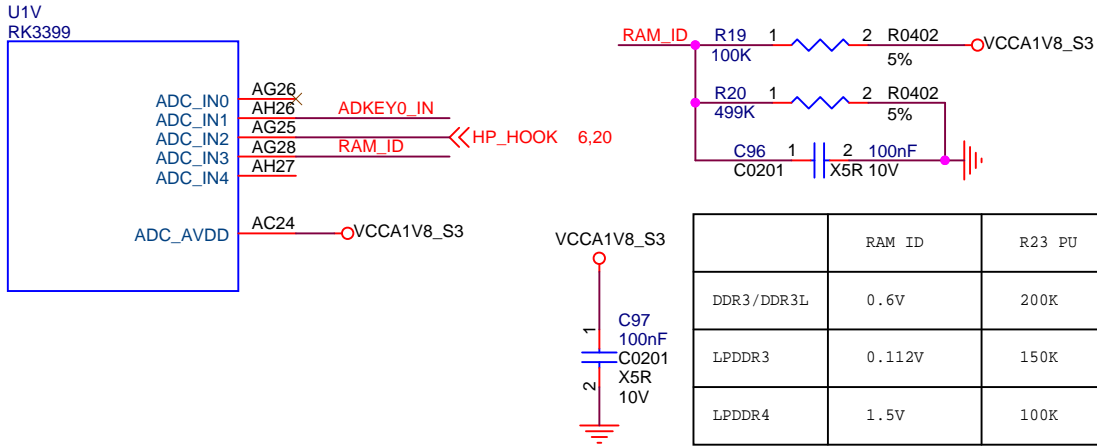

	RAM ID	R23 PU	R24 PD
DDR3/DDR3L	0.6V	200K	100K
LPDDR3	0.112V	150K	10K
LPDDR4	1.5V	100K	499K

Note:  
系统上电时, 如果ADKEY\_IN电平为0V,  
则RK3399进入Recovery模式;  
量产时R1503, SW1500, ED1500可以不用贴片。

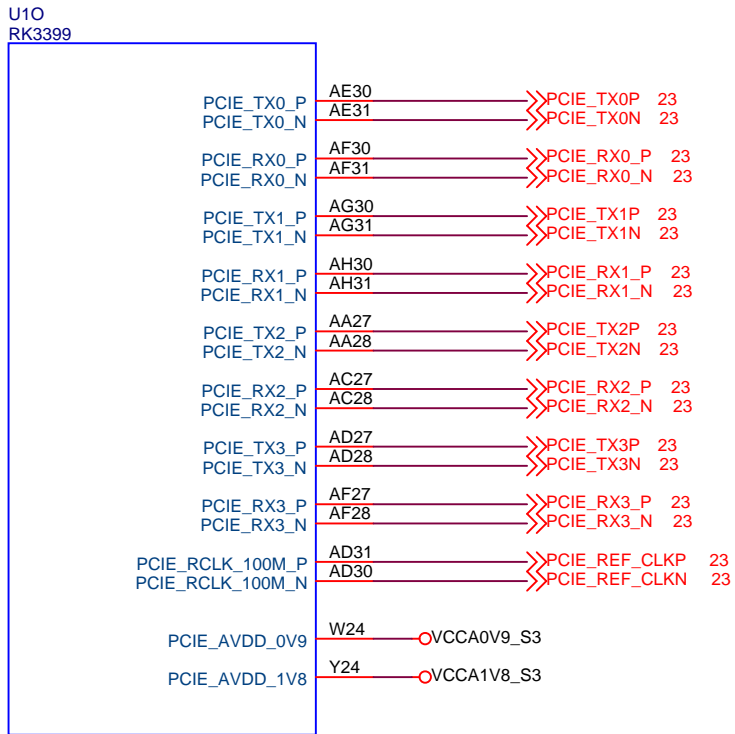
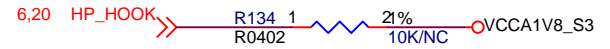
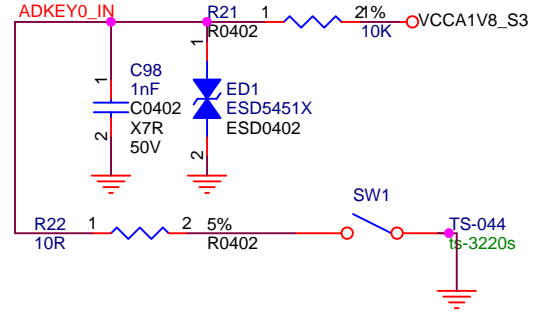

PINE64		<b>PINE64</b>	
Title Pinebook Pro			
Size A4	Document Number SARADC/KEY	Rev V2.1	
Date:	Sheet 6 of 23		

U1L  
RK3399

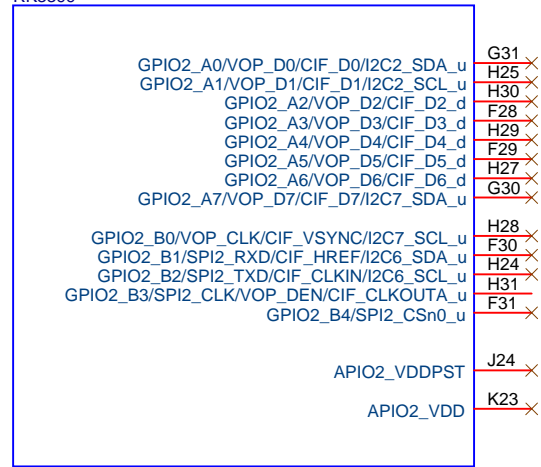

U1R  
RK3399

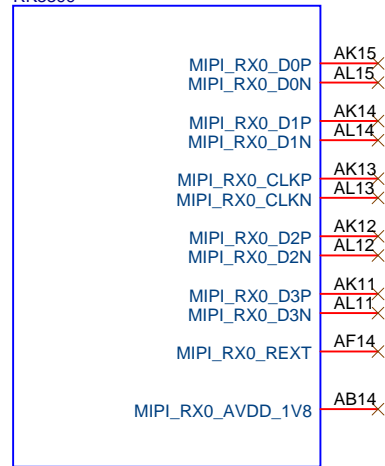

U1P  
RK3399

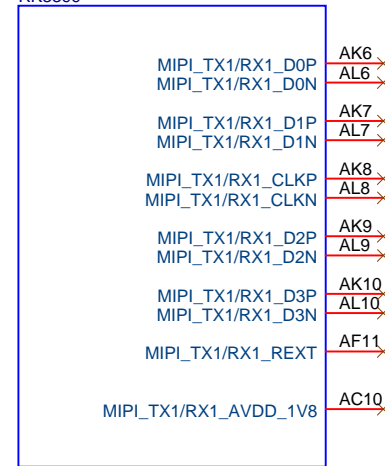

		<b>PINE64</b>	
Title			
Pinebook Pro			
Size	Document Number		Rev
A4	DVP interface		V2.1
Date:	Sheet 7 of 23		



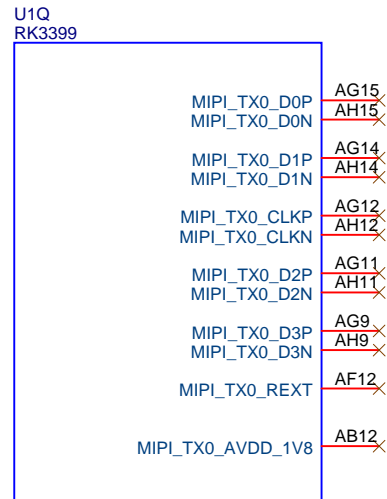
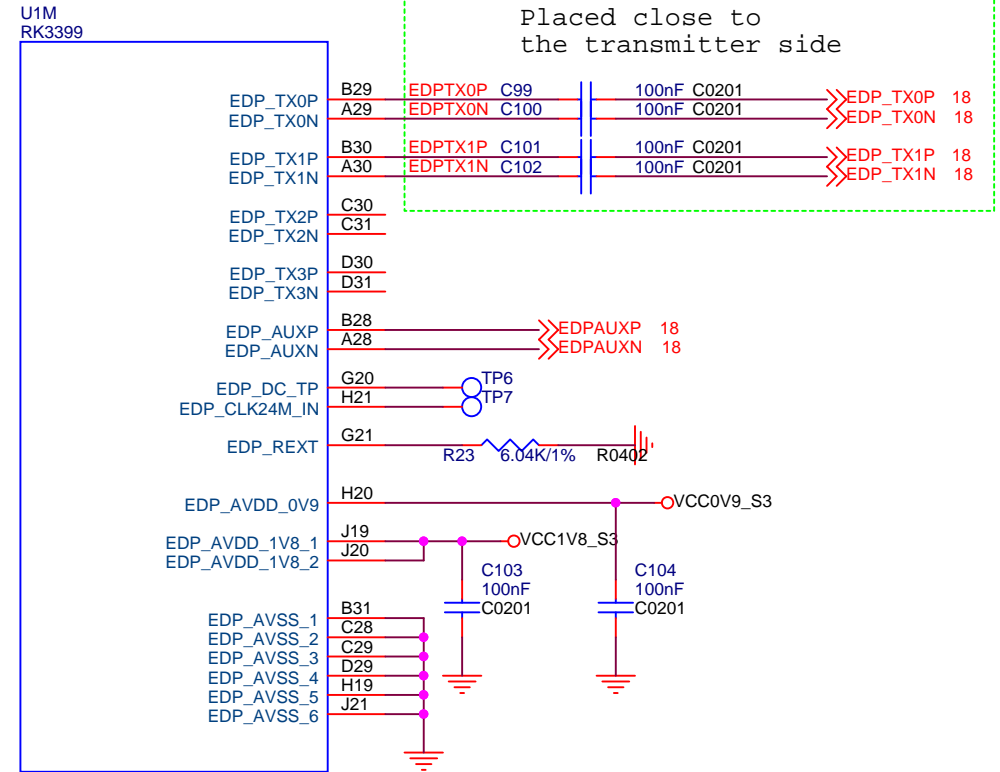
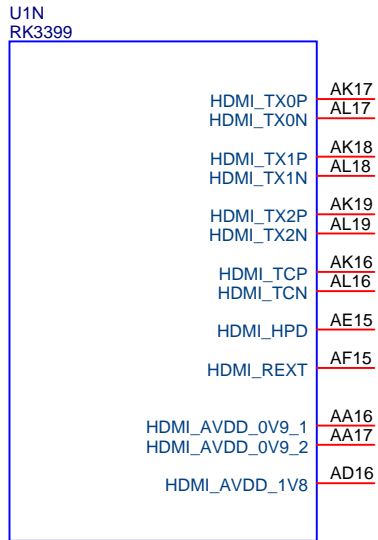

eDP design rule:

1. Max intra-pair skew < 4 ps;
2. Max trace length < 6 inches;
3. Max allowed via < 4;
4. Trace impedance 90ohm+/-10%;
5. 与其他信号间距遵循3W原则;

PINE64		<b>PINE64</b>	
Title			
Pinebook Pro			
Size	Document Number		Rev
A4	Display interface		V2.1
Date:	Sheet 8 of 23		

U1I Note:RK3399 part I is 3.3V only

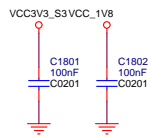
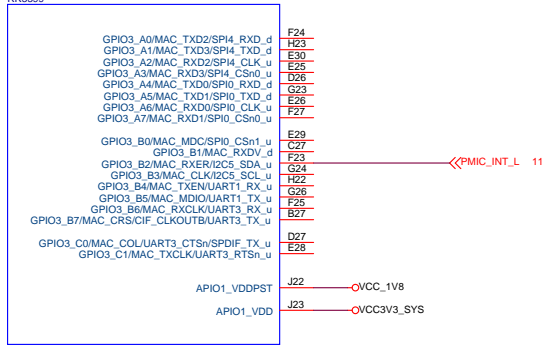

U1E Note:RK3399 part E is 1.8V/3.0V mode

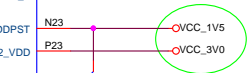
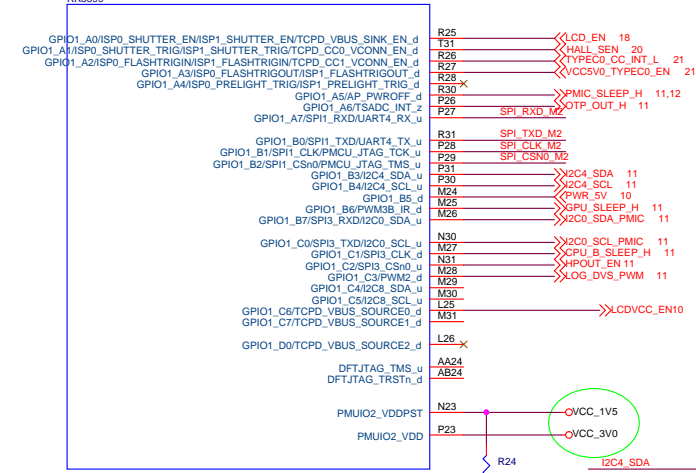

1.8V Only	VDDPST=VDDIO=1.8V
3.3V Only	VDDPST=1.8V, VDDIO=3.3V
other	3.0V mode:VDDPST=1.5V, VDDIO=3.0V 1.8V mode:VDDPST=1.8V, VDDIO=1.8V

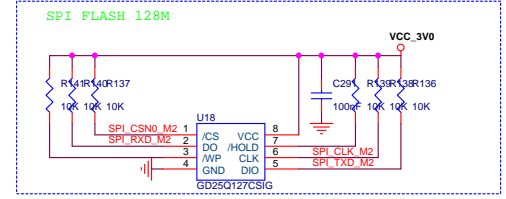
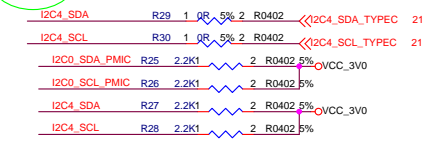

U1G Note:RK3399 part G is 1.8V only

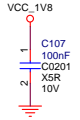
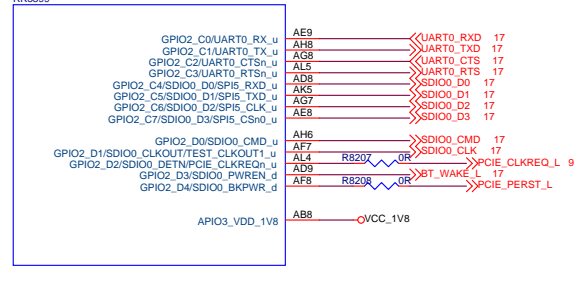

U1K Note:RK3399 part J is 1.8V/3.0V mode

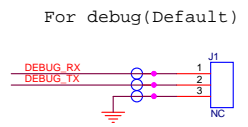
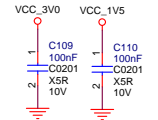
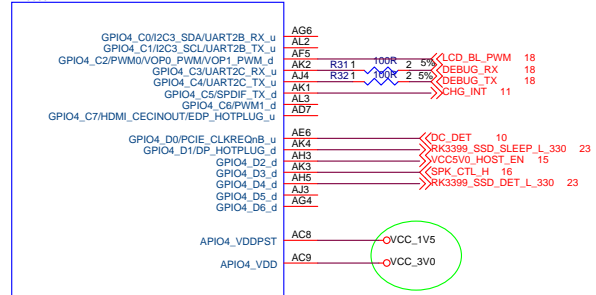

U1J Note:RK3399 part J is 1.8V/3.0V mode

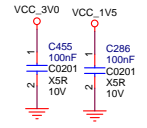
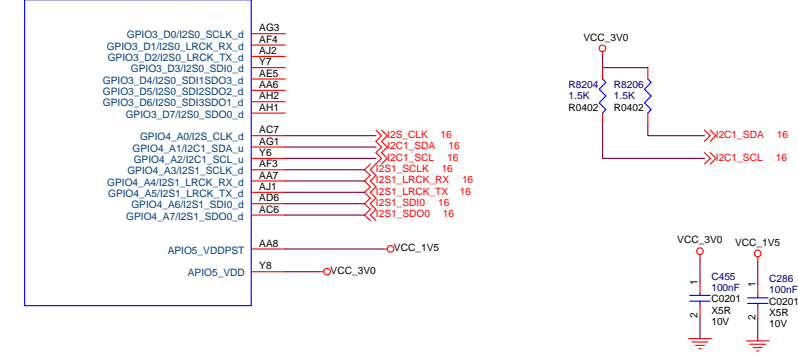

### DC IN 5V 3A

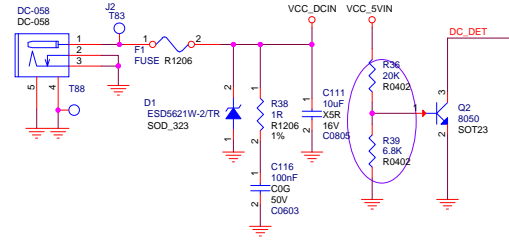

## CHARGE and Power Path

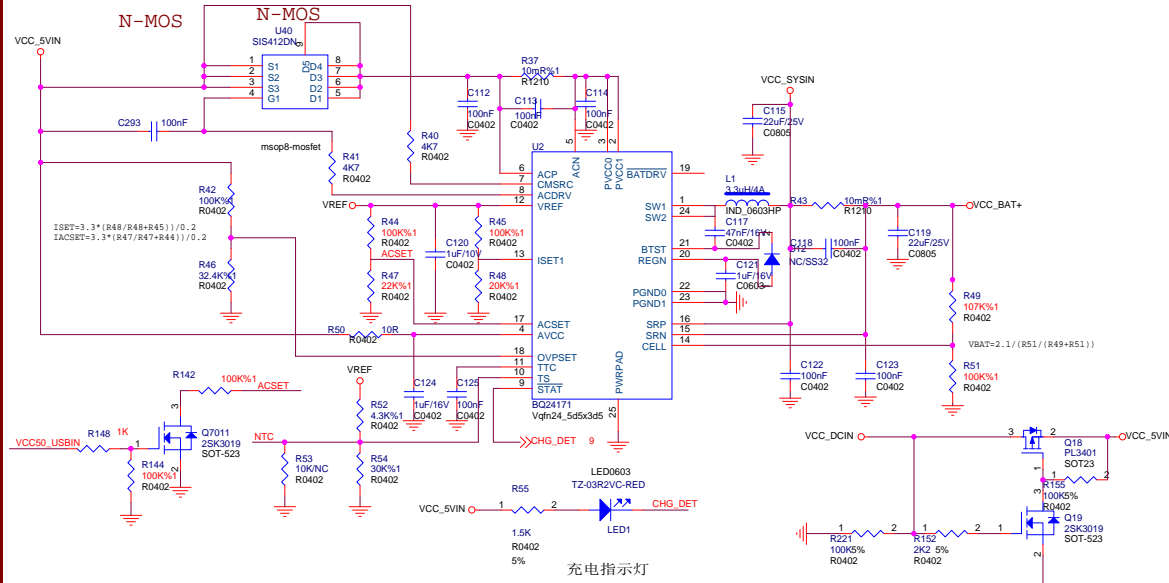

### BATTAR 单节3.8V 9000mAh

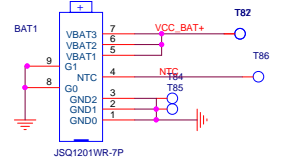

### 3.3V SYSTEM

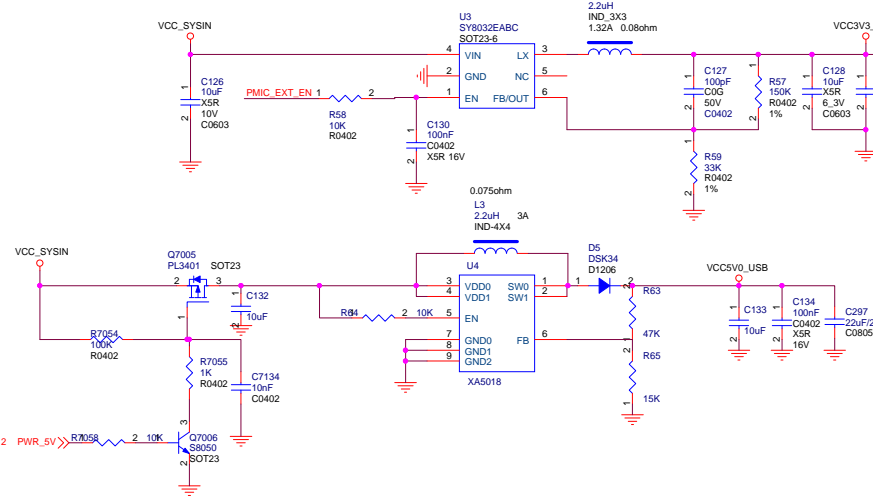

### Power Path Management

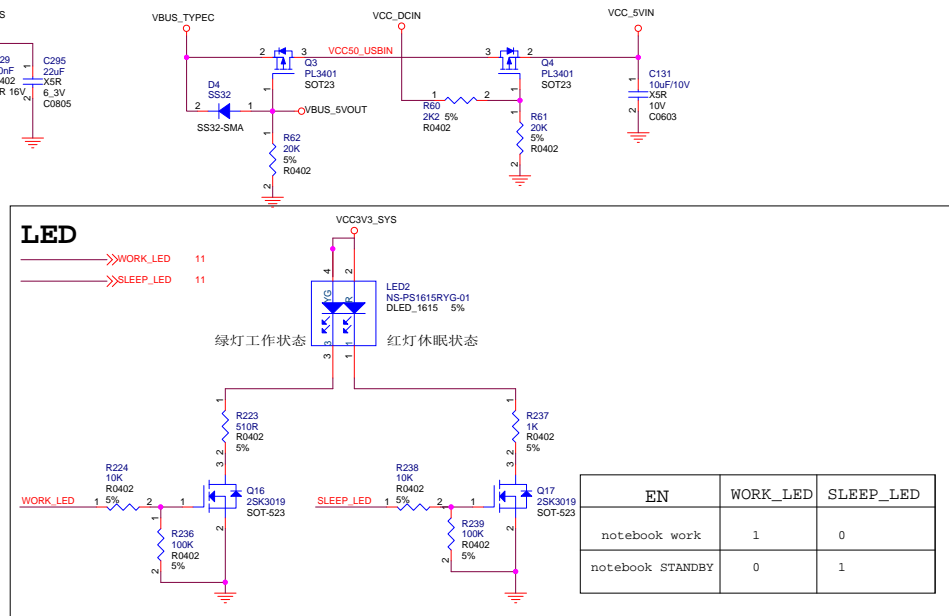

EN	WORK_LED	SLEEP_LED
notebook work	1	0
notebook STANDBY	0	1

# PMIC

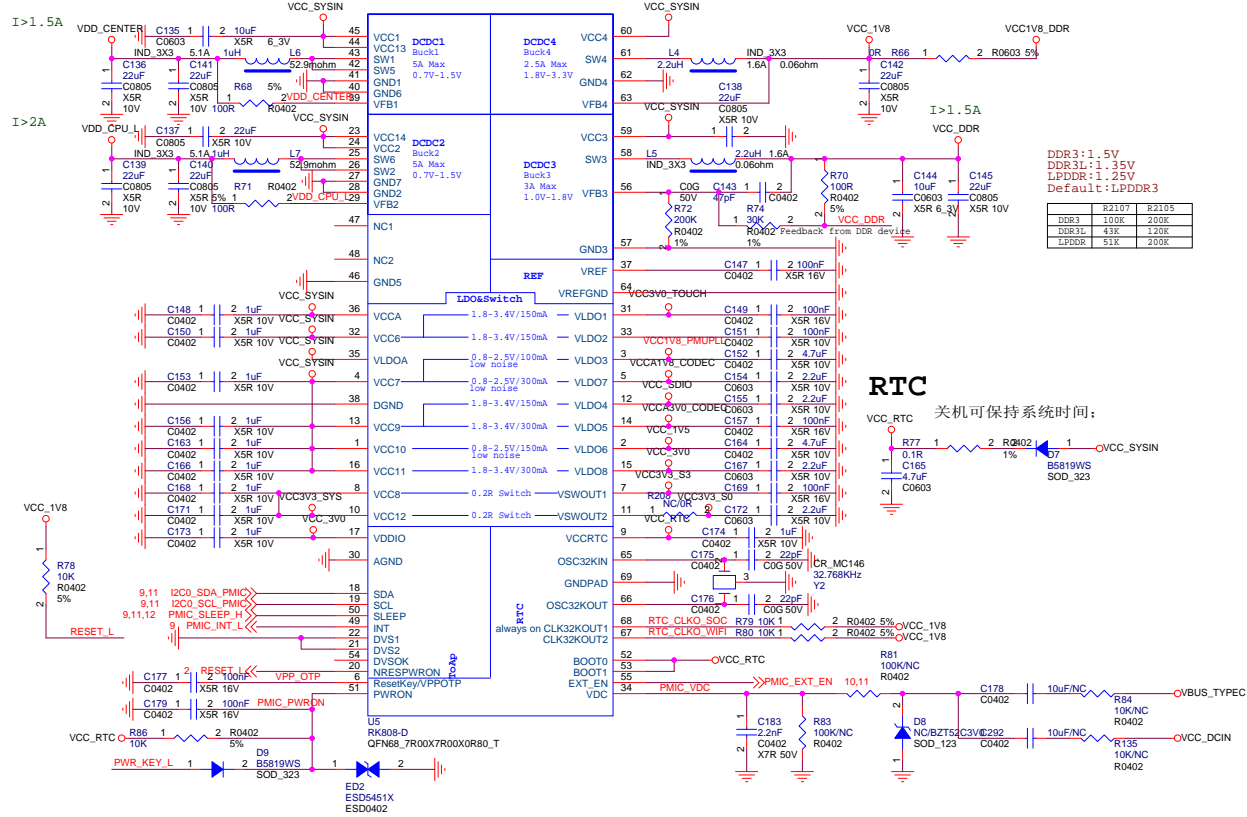

# Over-temperature Protection

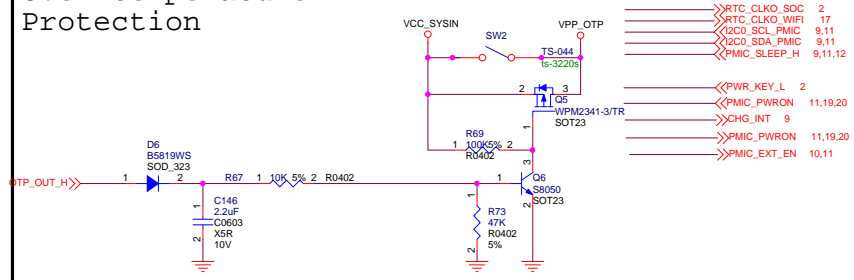

# VDD\_CPU\_B power

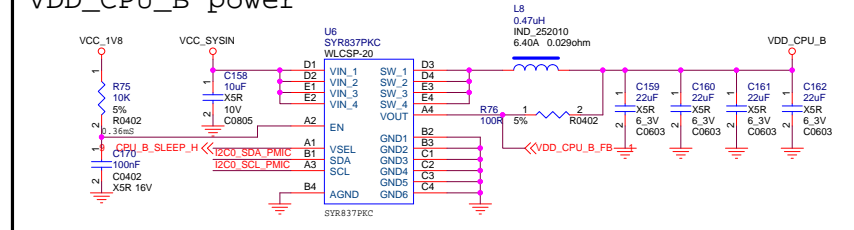

# VDD\_GPU power

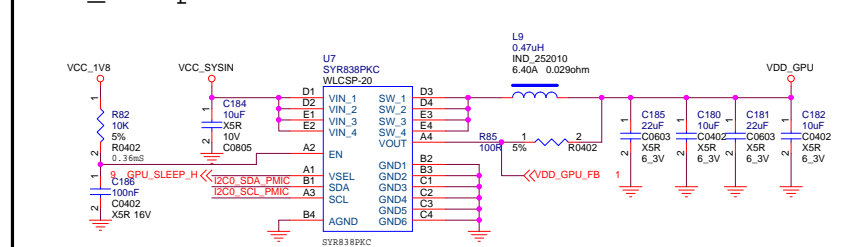

# VDD\_LOG power

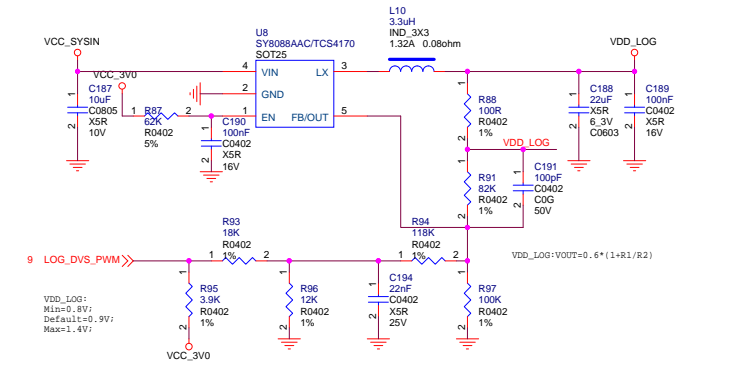

# Gas Gauge

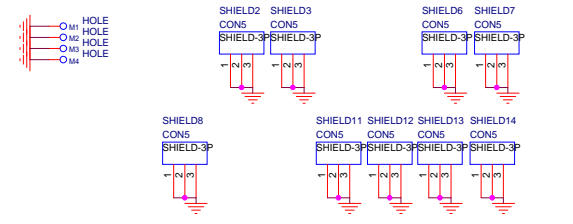
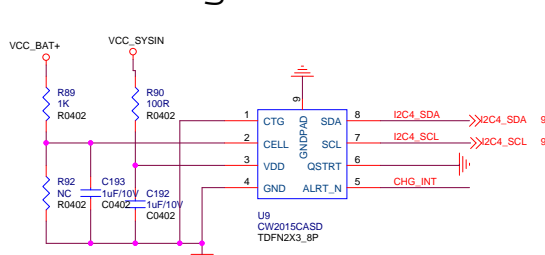

PINE64		<b>PINE64</b>	
Title	Pinebook Pro		
Size	Document Number		Rev
Custom	RK808-D 1		V2.1
Date:		Sheet	11 of 23

### VCC\_0V9 power

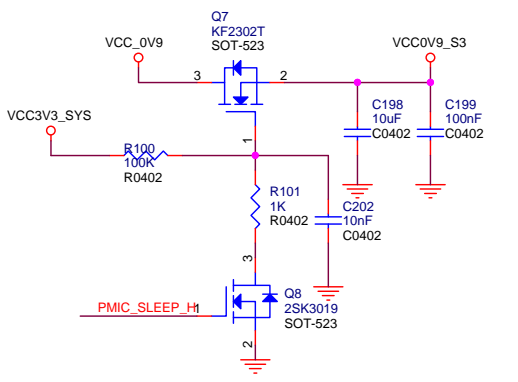
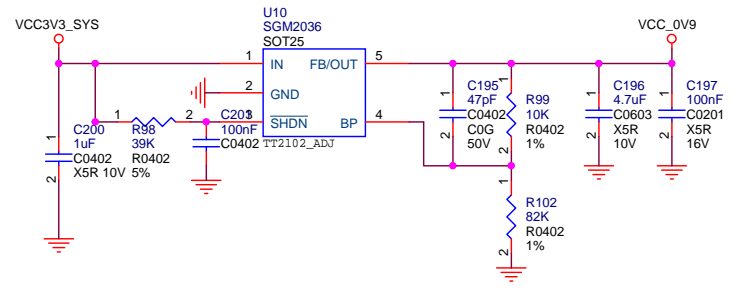

### VCC\_1V8 power

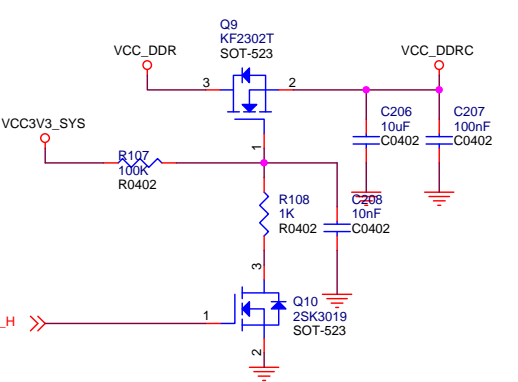
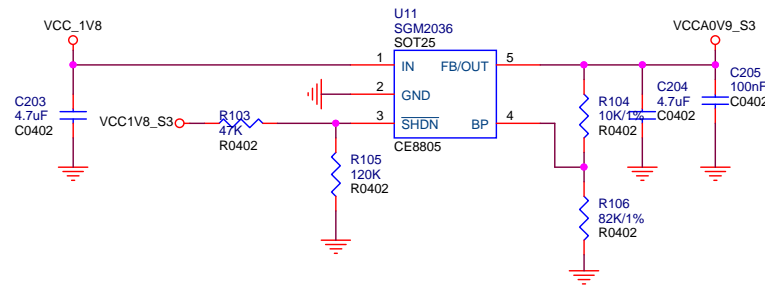

### VCCA1V8\_S3 power

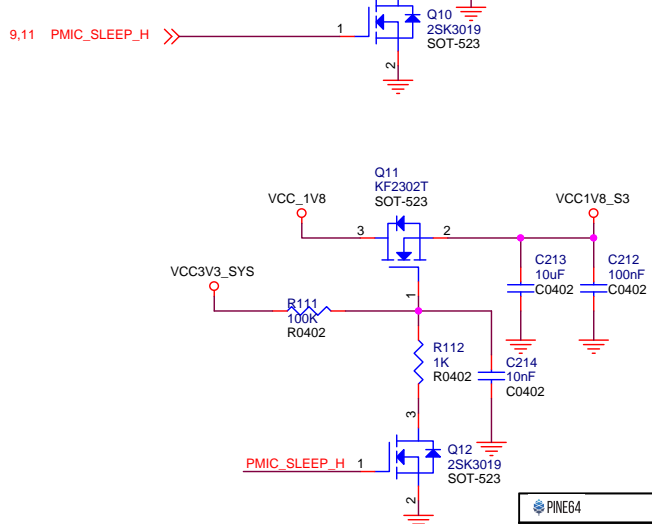
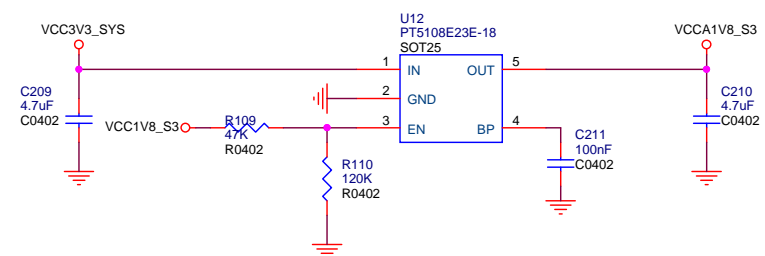

### VCC3V0\_SD power

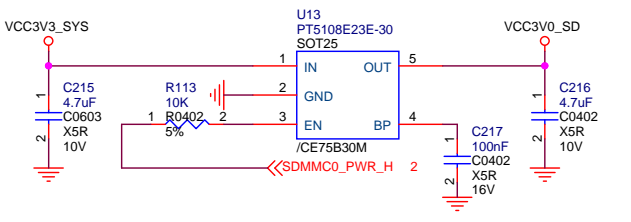

PINE64		<b>PINE64</b>	
Title Pinebook Pro			
Size B	Document Number	Rev	
	RK808-D 2	V2.1	
Date:	Sheet	12	of 23

# LPDDR4

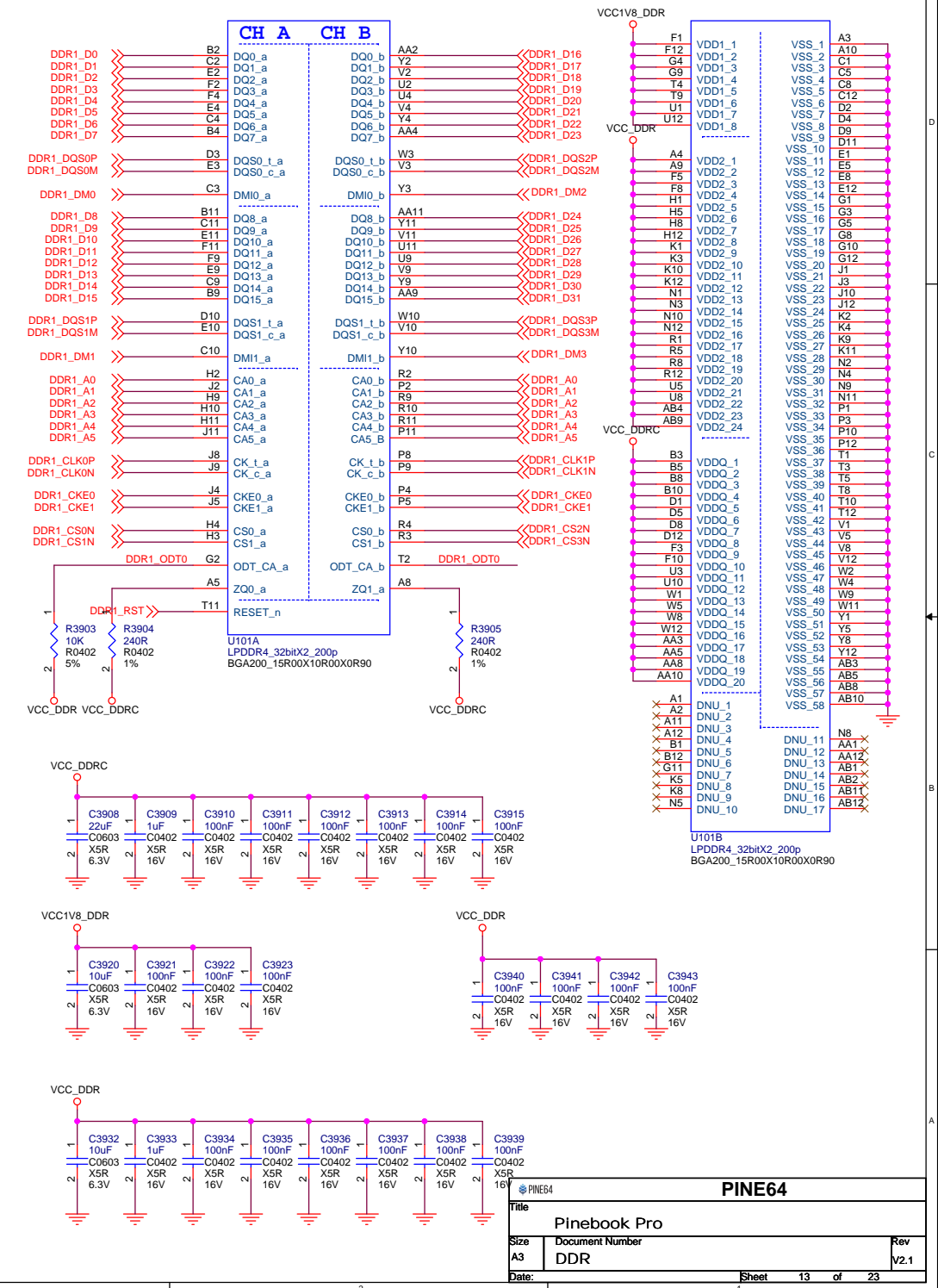
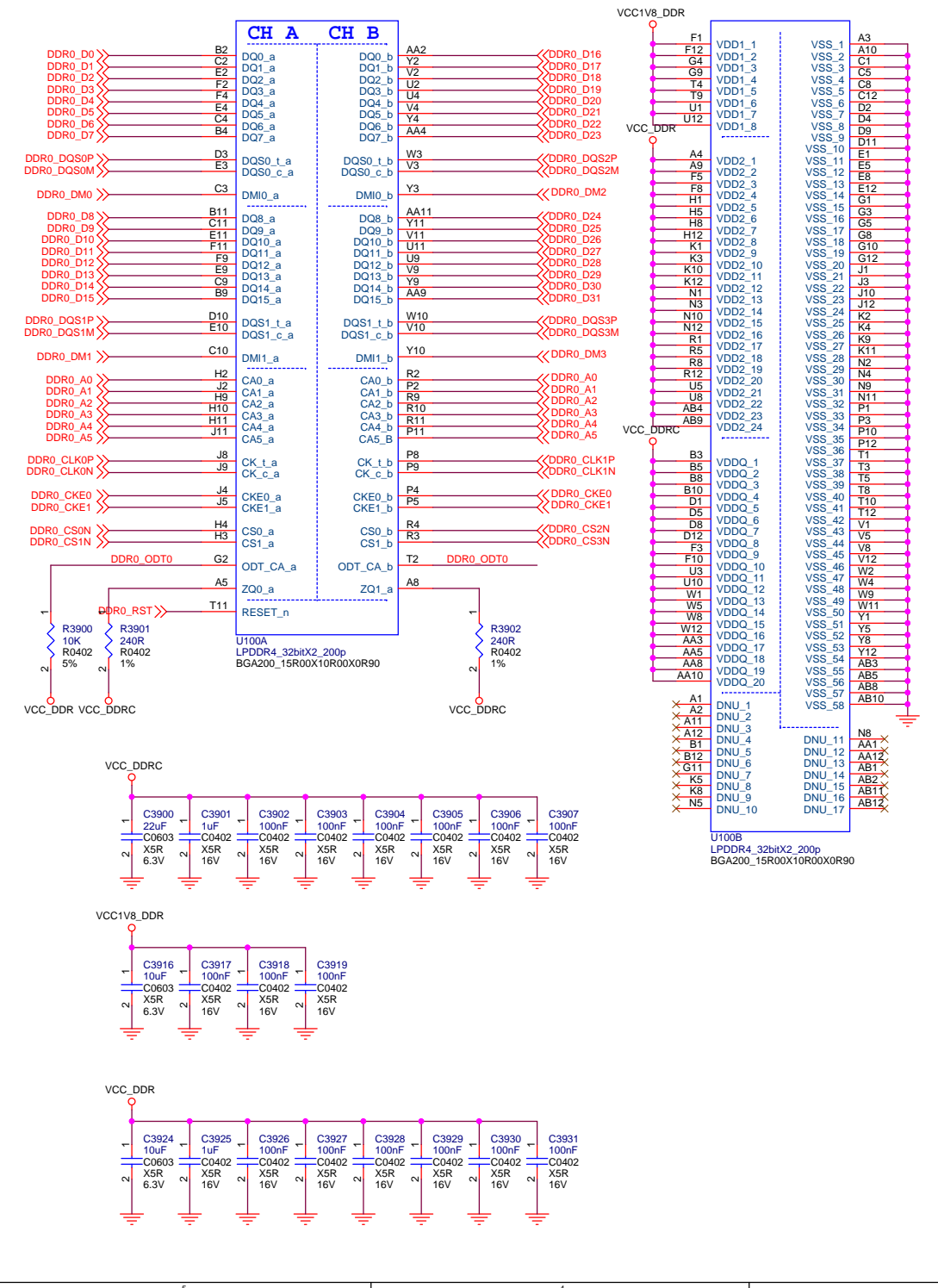

# eMMC Port

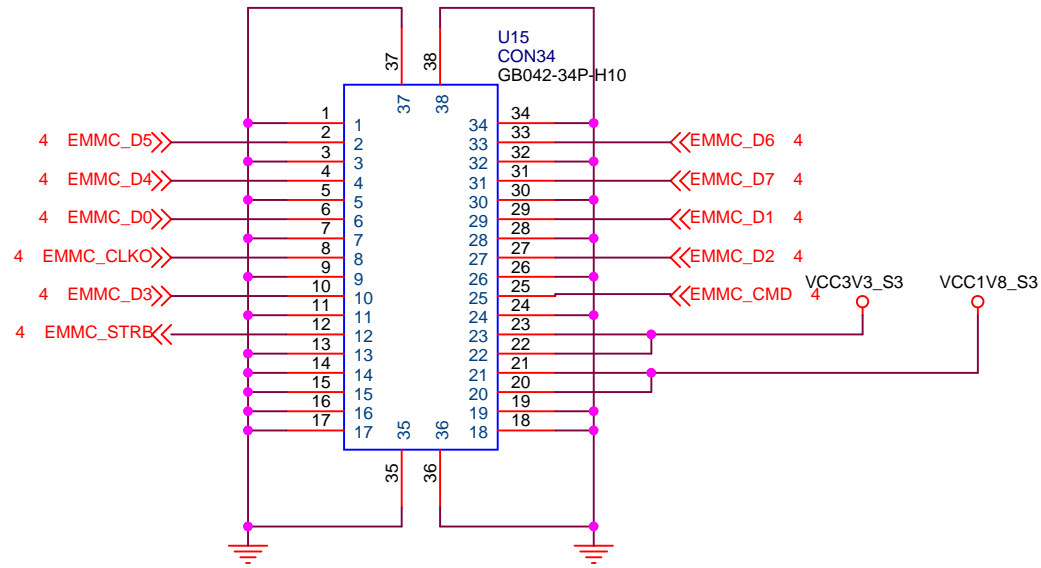

Note:  
Reserve SW for Update.

SEL	Shunt Status	Function
1	OFF	eMMC
ON	ON	MASKROM

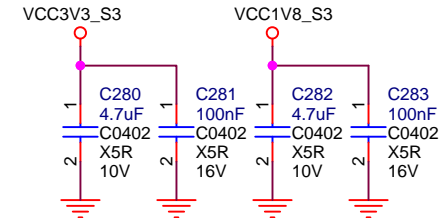

PINE64		<b>PINE64</b>	
Title Pinebook Pro			
Size A4	Document Number EMMC		Rev V2.1
Date:		Sheet 14 of 23	

# USB3.0 OTG port

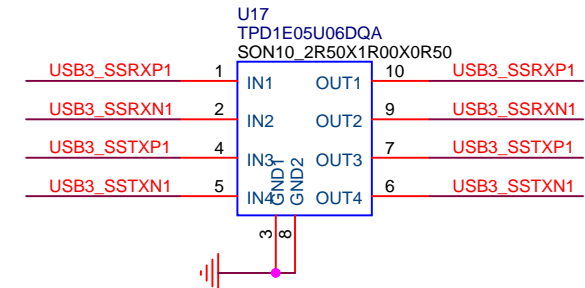
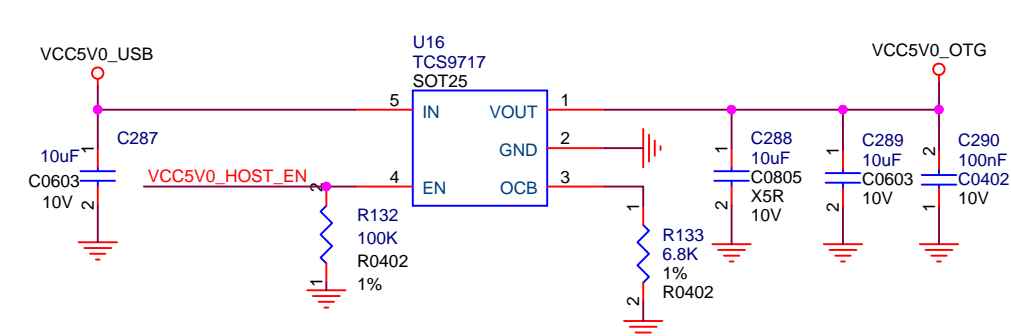
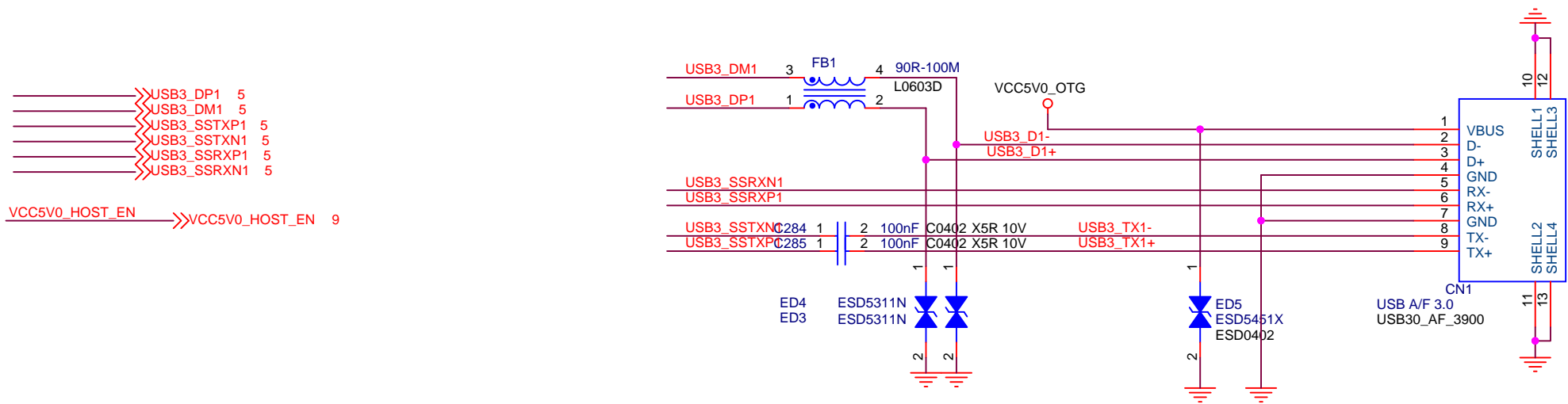

<b>PINE64</b>	
<b>Title</b> Pinebook Pro	
<b>Size</b> A4	<b>Document Number</b> USB 3.0
<b>Date:</b>	<b>Rev</b> V2.1
Sheet 15 of 23	



# CODEC

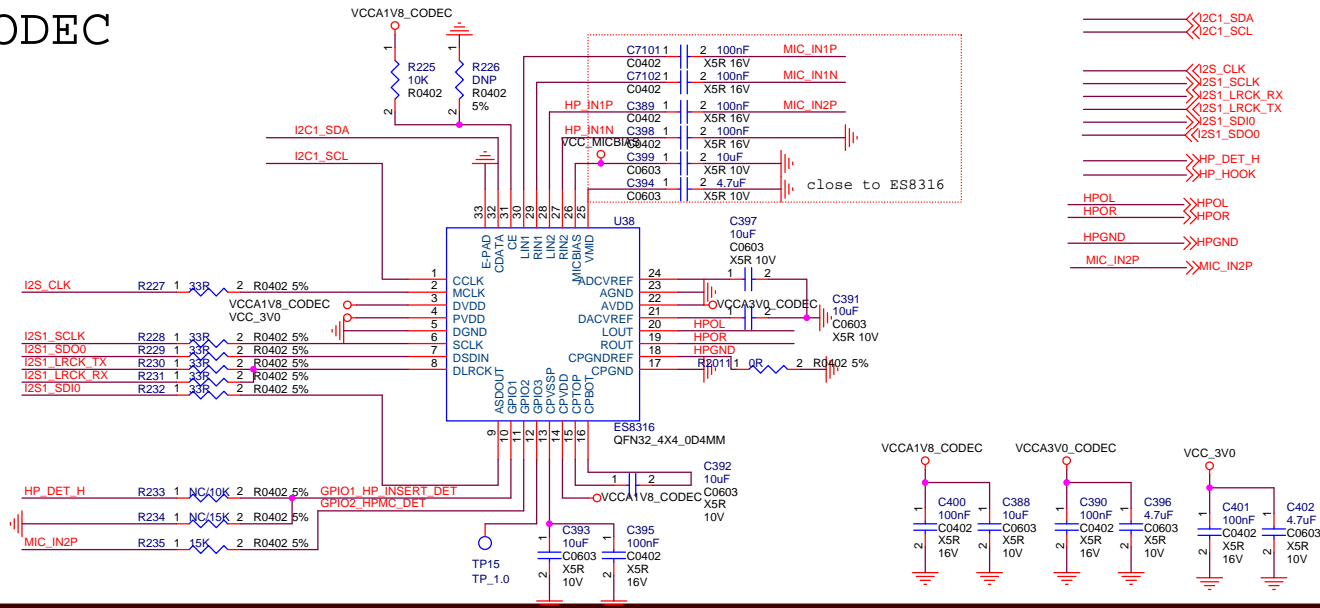

- >>>I2C1\_SDA
- >>>I2C1\_SCL
- >>>I2S\_CLK
- >>>I2S1\_SCLK
- >>>I2S1\_LRCK\_RX
- >>>I2S1\_LRCK\_TX
- >>>I2S1\_SDIO
- >>>I2S1\_SD00
- >>>HP\_DET\_H
- >>>HP\_HOOK
- >>>HPOL
- >>>HPOR
- >>>HPGND
- >>>MIC\_IN2P

# SPEAKER

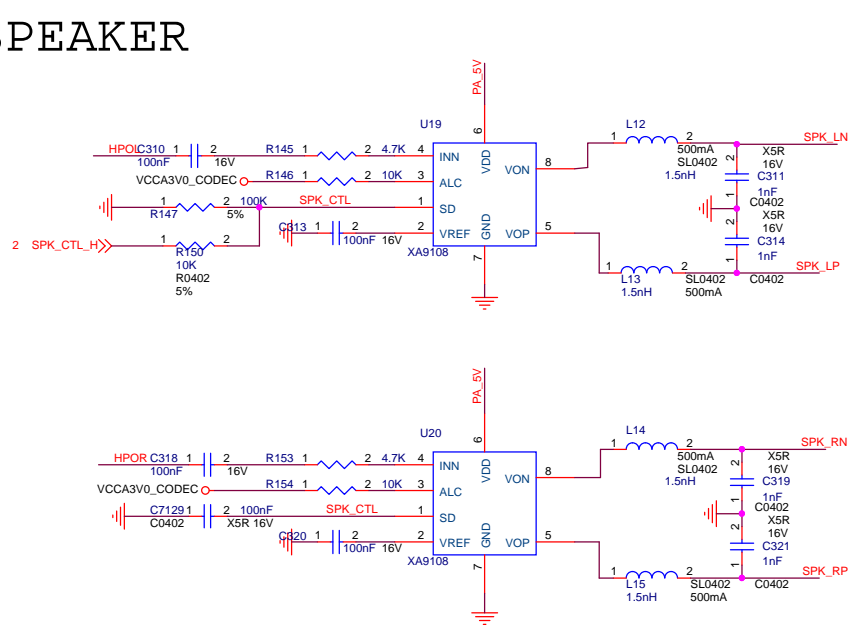

# MIC

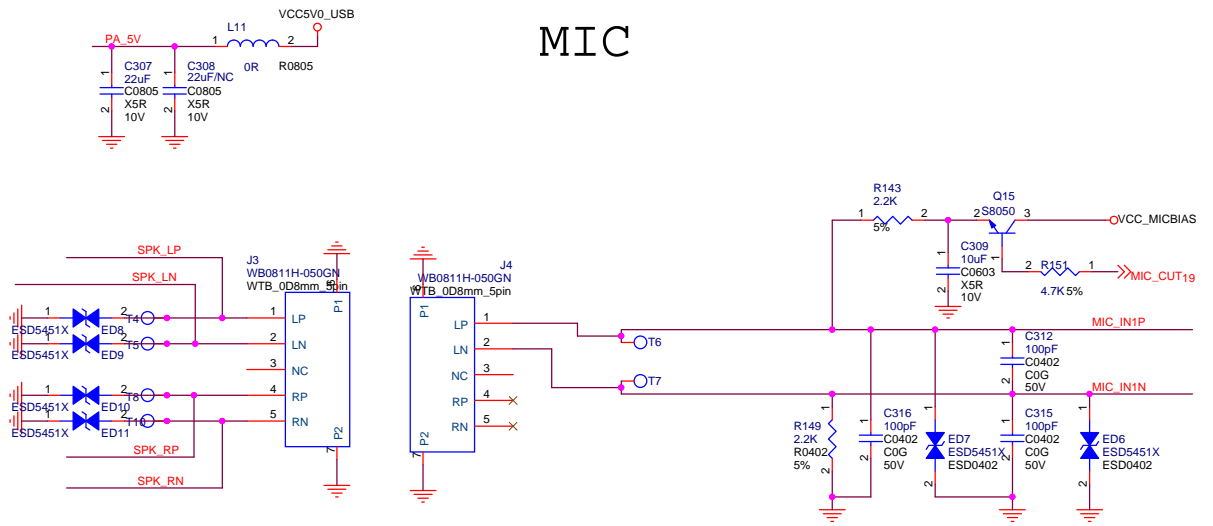

PINE64		<b>PINE64</b>	
Title: Pinebook Pro			
Size: Document Number			Rev: V2.1
Custom: ES8316			
Date:	Sheet 16 of 23		

# WIFI/BT MODULE

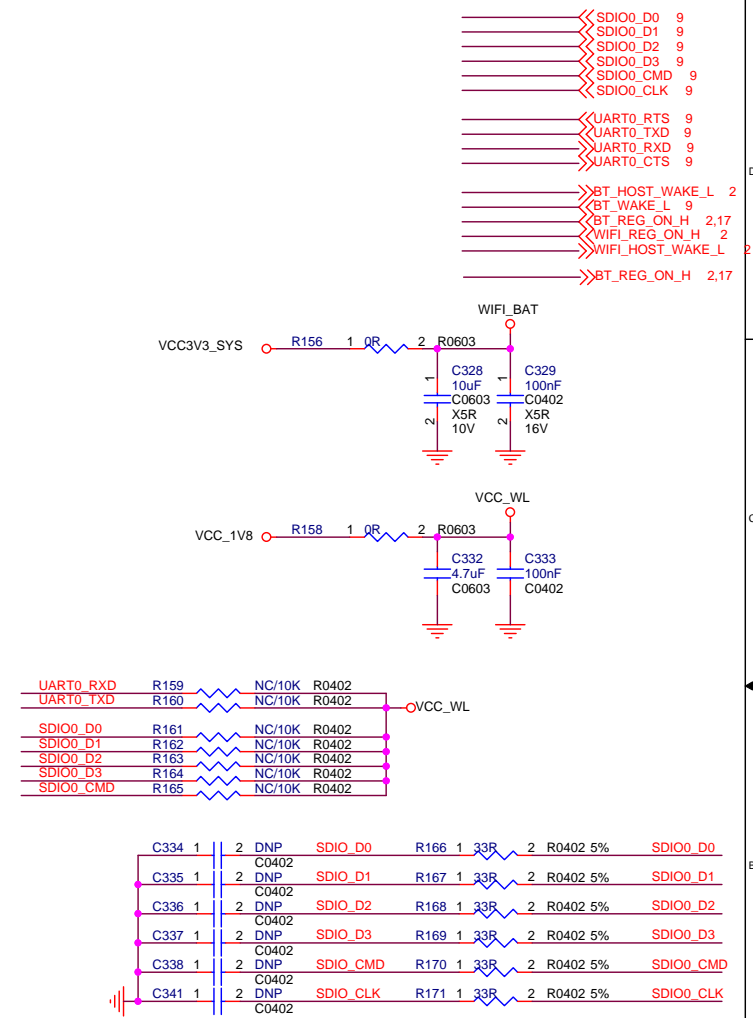
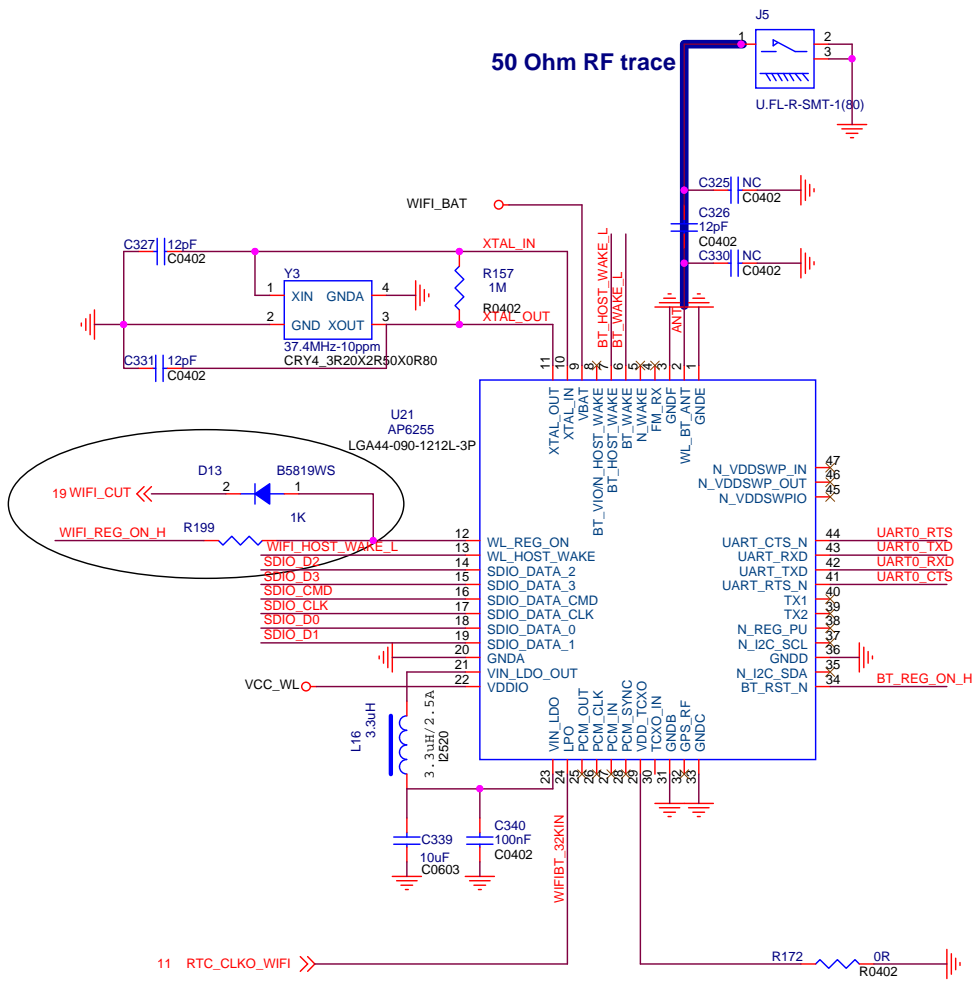

		<b>PINE64</b>	
<b>Title</b> Pinebook Pro			
<b>Size</b> B	<b>Document Number</b> WIFI		<b>Rev</b> V2.1
<b>Date:</b>	Sheet 17 of 23		

# CAM POWER

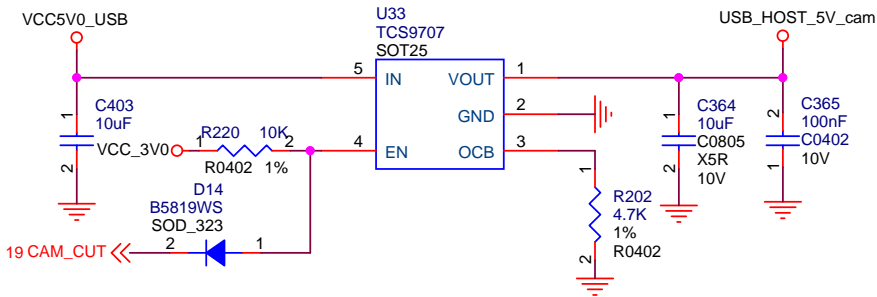

# eDP Panel

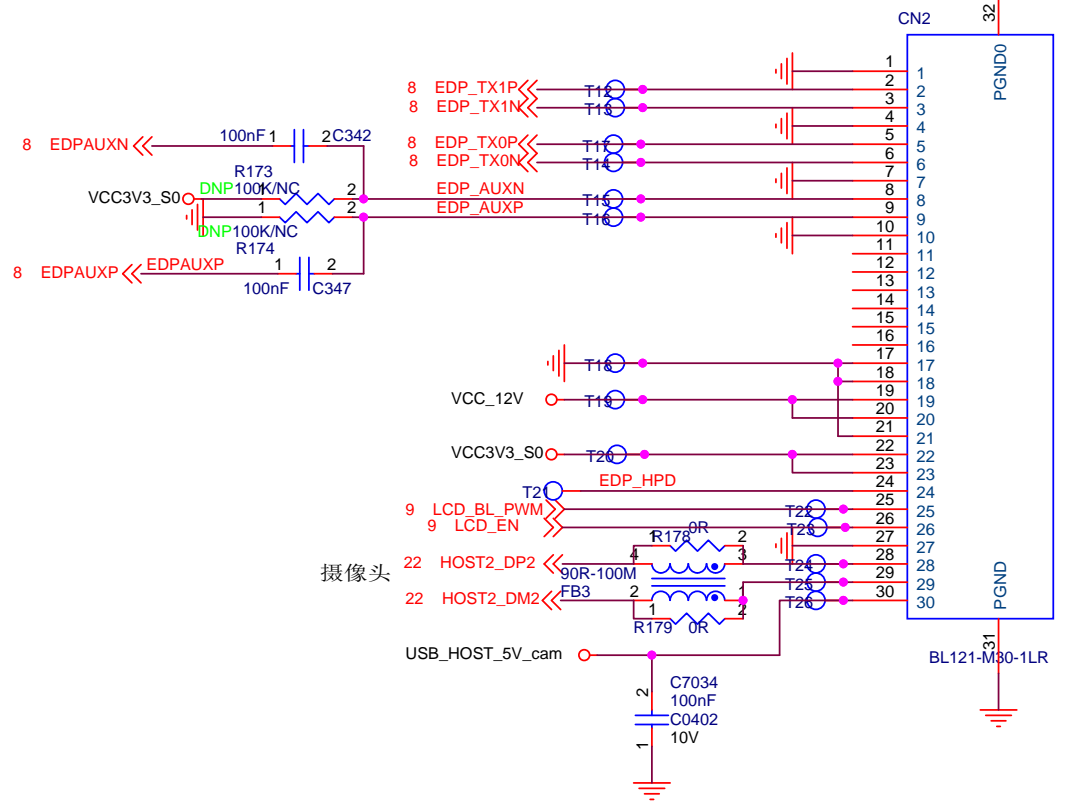

# LCD DRIVER

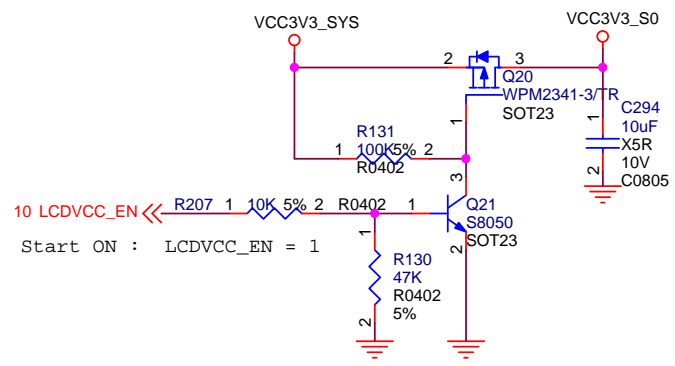

# BACKLIGHT

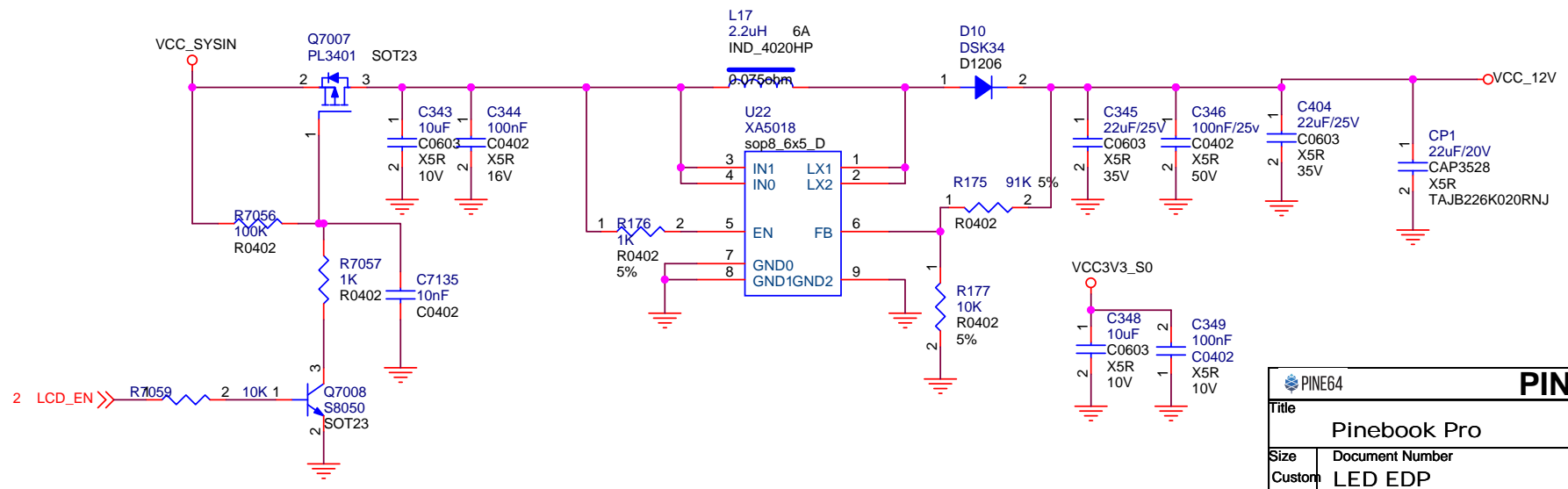

PINE64		<b>PINE64</b>	
Title Pinebook Pro			
Size	Document Number	Rev	
Custom	LED EDP	V2.1	
Date:	Sheet	18	of 23

# KEY Board Click Pad

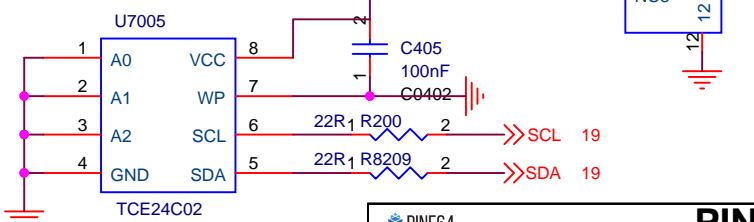
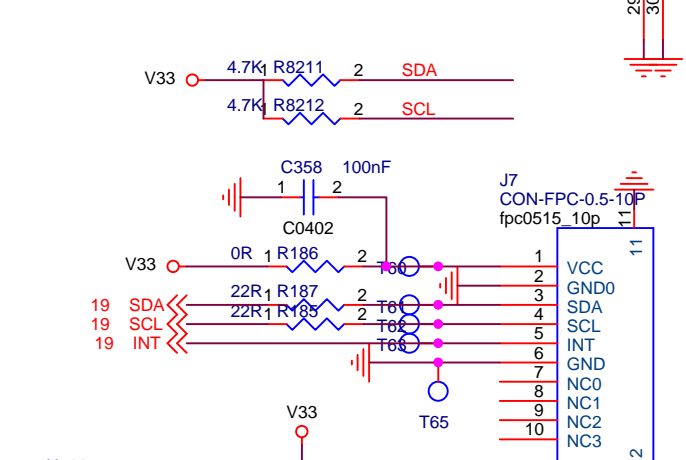
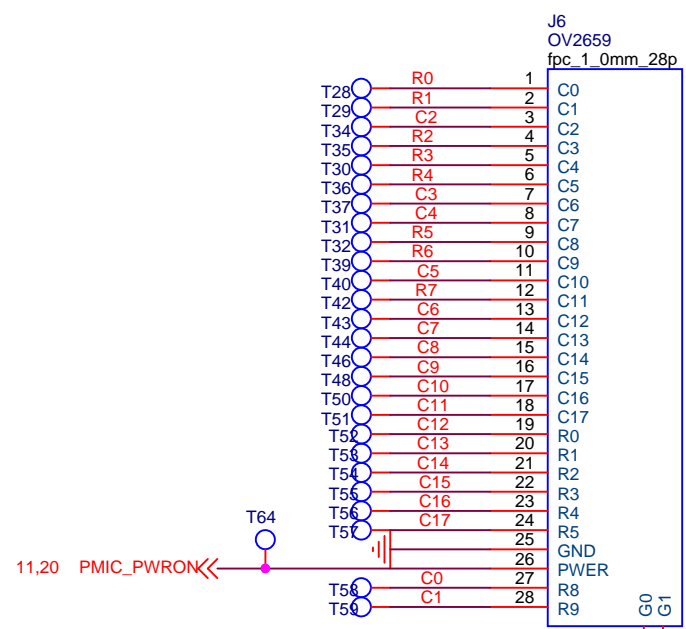
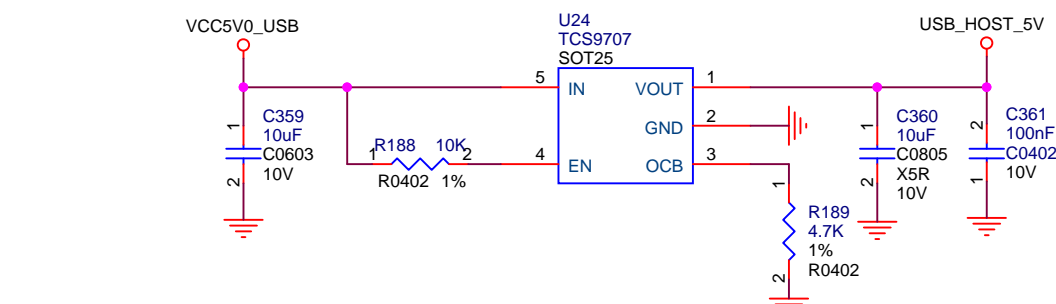
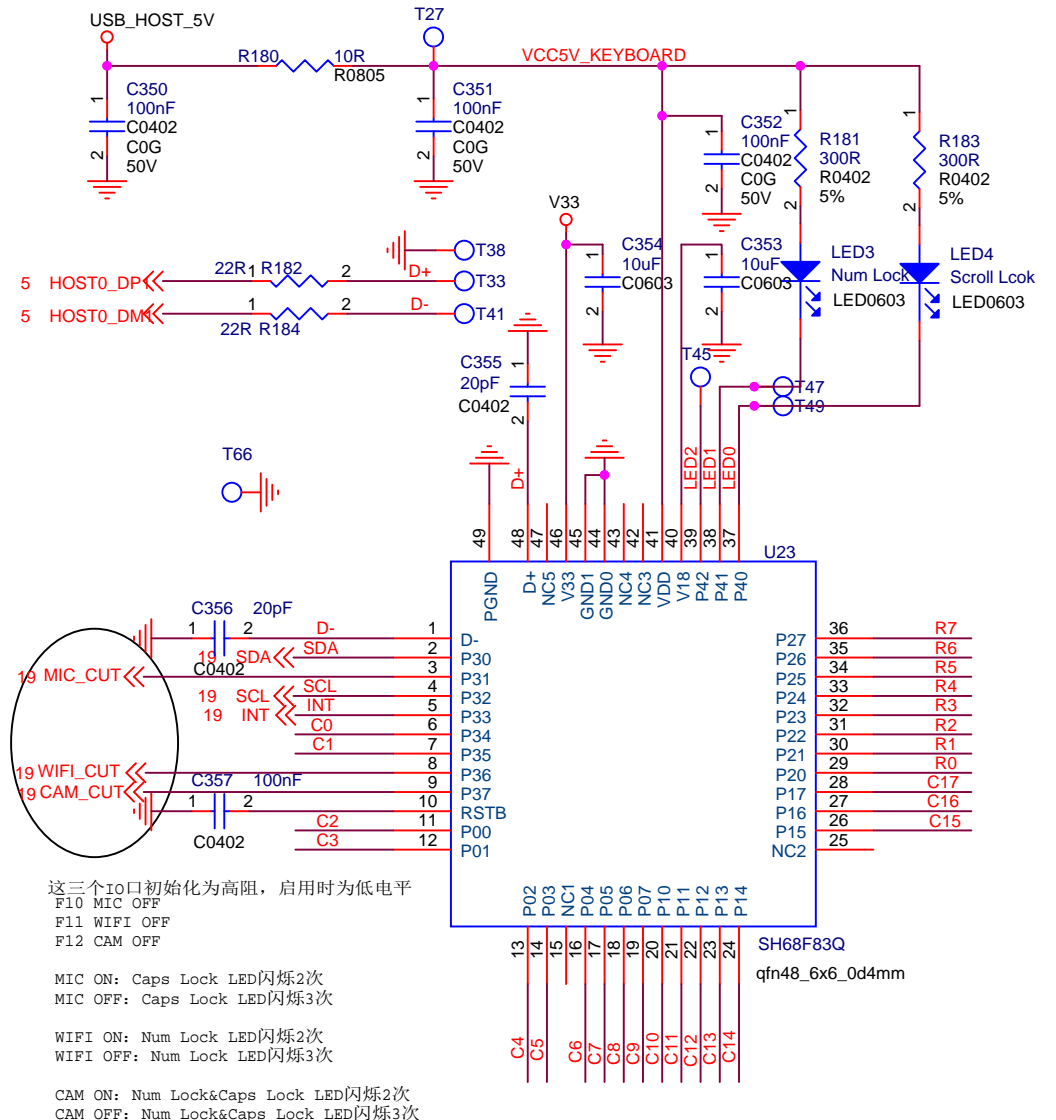

这三个IO口初始化为高阻，启用时为低电平  
 F10 MIC OFF  
 F11 WIFI OFF  
 F12 CAM OFF

MIC ON: Caps Lock LED闪烁2次  
 MIC OFF: Caps Lock LED闪烁3次

WIFI ON: Num Lock LED闪烁2次  
 WIFI OFF: Num Lock LED闪烁3次

CAM ON: Num Lock&Caps Lock LED闪烁2次  
 CAM OFF: Num Lock&Caps Lock LED闪烁3次

<b>PINE64</b>		<b>PINE64</b>
Title <b>Pinebook Pro</b>		
Size A4	Document Number <b>KEY Board Click Pad</b>	Rev V2.1
Date:	Sheet	19 of 23

小板连接器：耳机、SD卡、USB

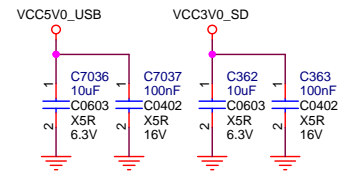
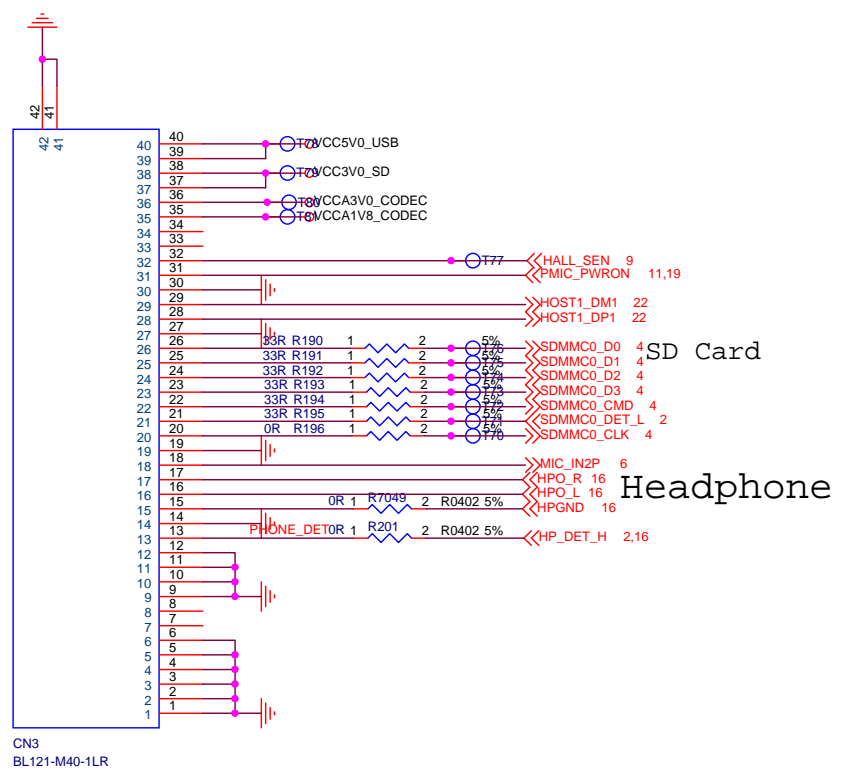

IN	NO	NC
0	OFF	ON
1	ON	OFF

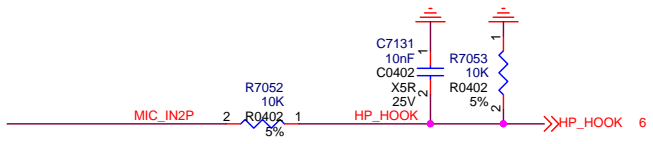
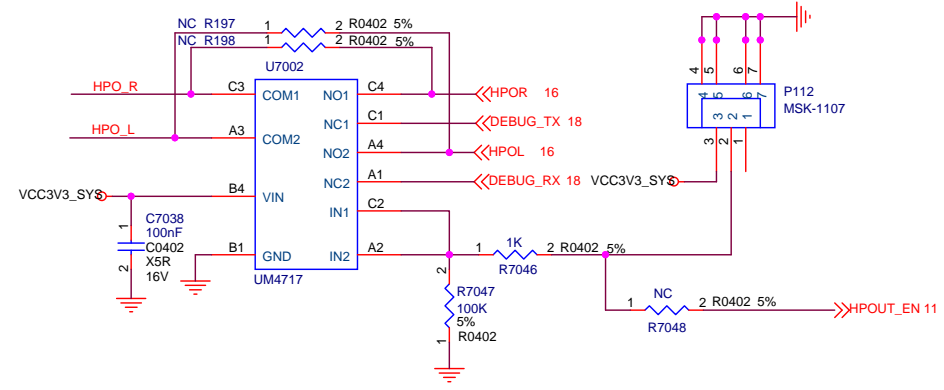

# USB Type-C port

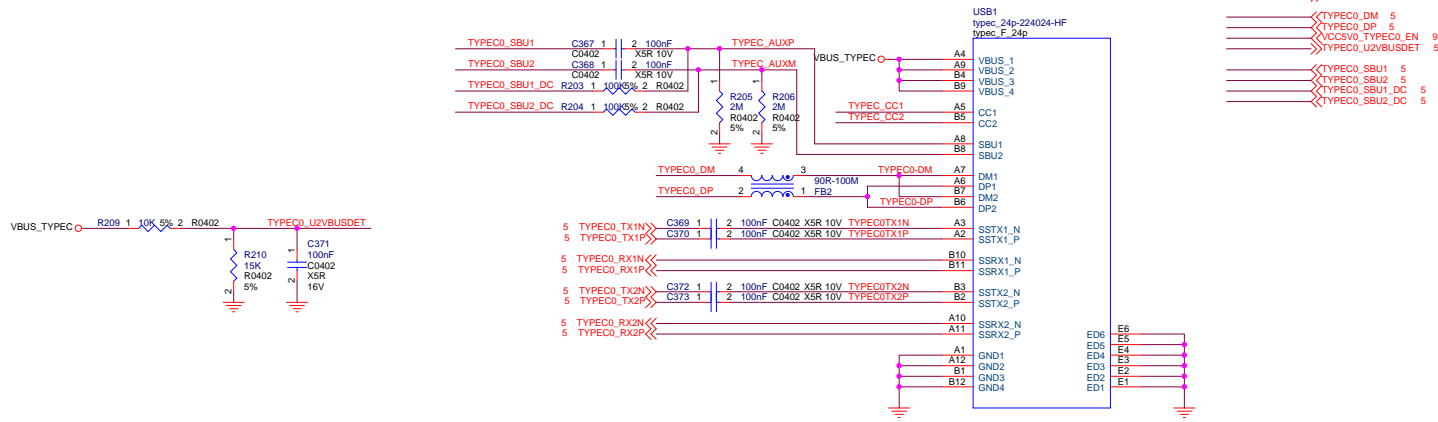

## CC CTRL

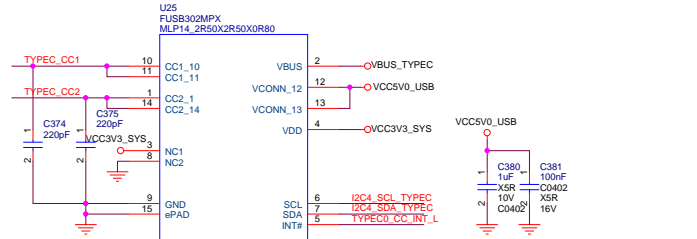

## Limit switch

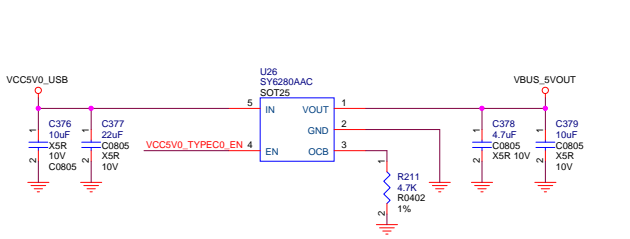

## ESD



# USB HUB

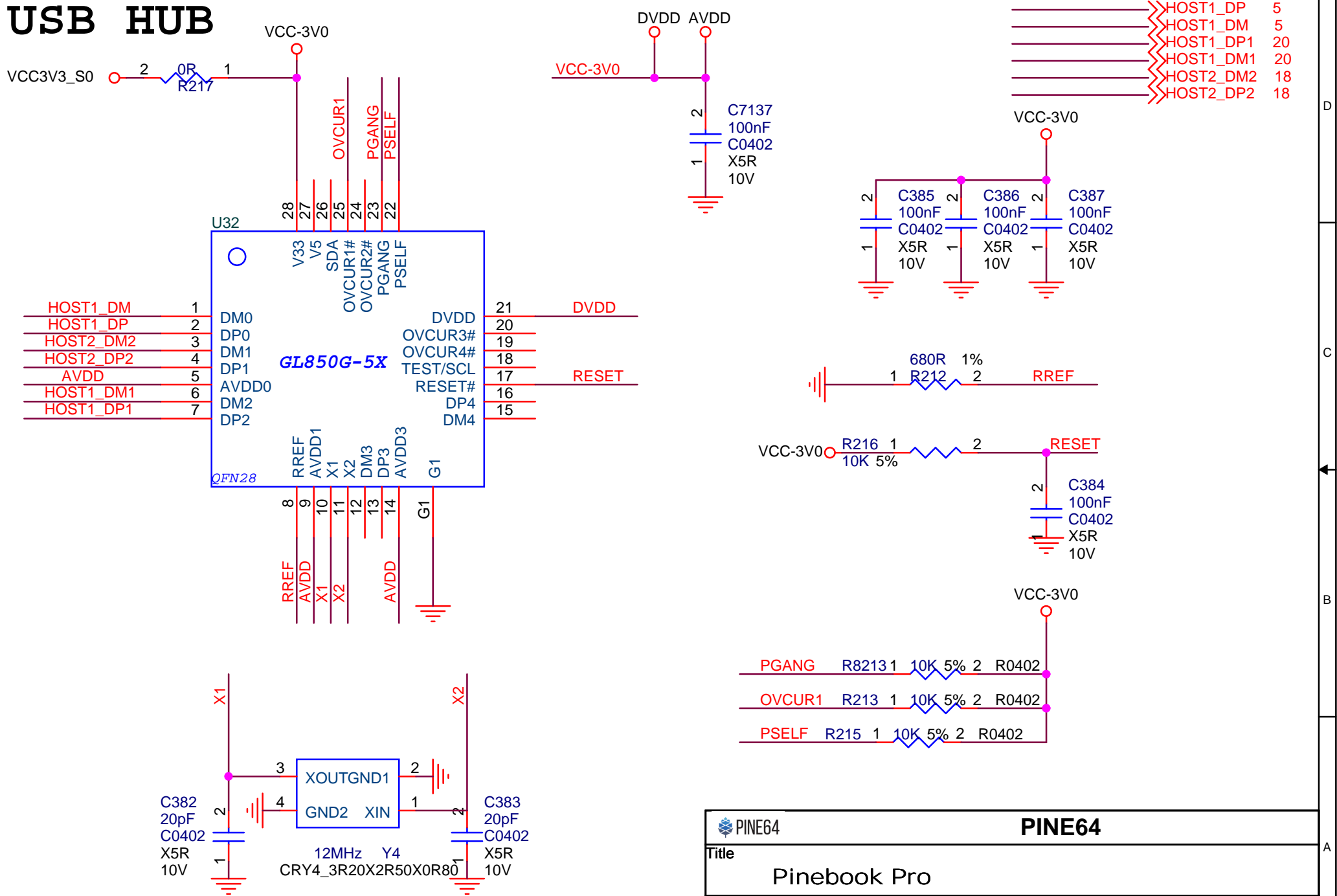

PINE64		<b>PINE64</b>	
Title <b>Pinebook Pro</b>			
Size Custom	Document Number <b>USB HUB</b>		Rev <b>V2.1</b>
Date:		Sheet <b>22</b>	of <b>23</b>

# NGFF M.2 FPC

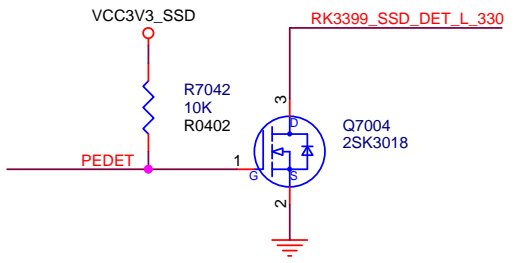
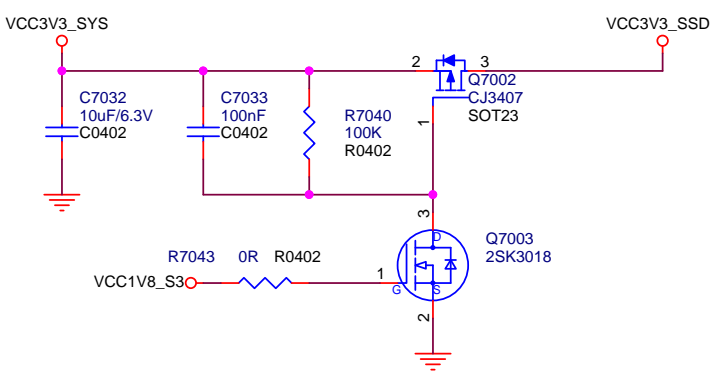
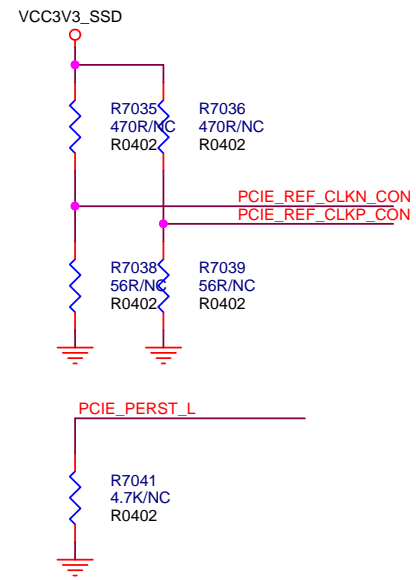
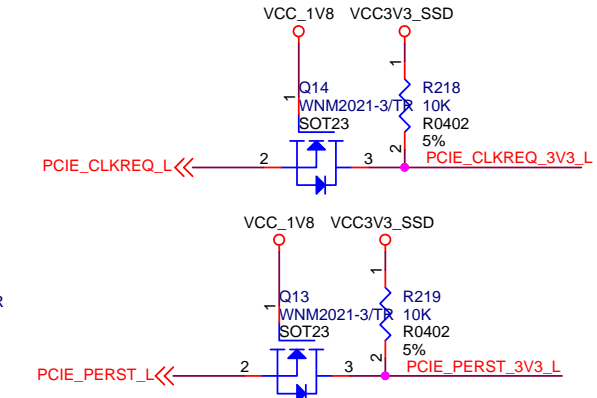
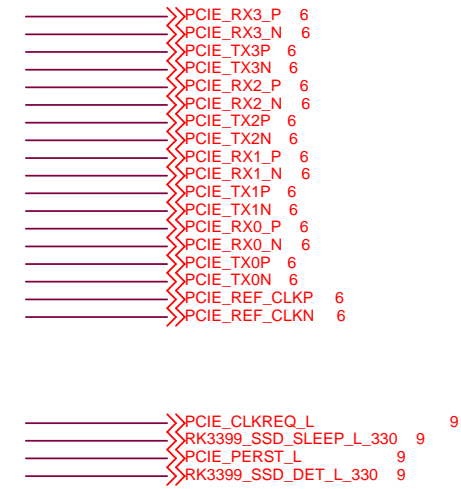
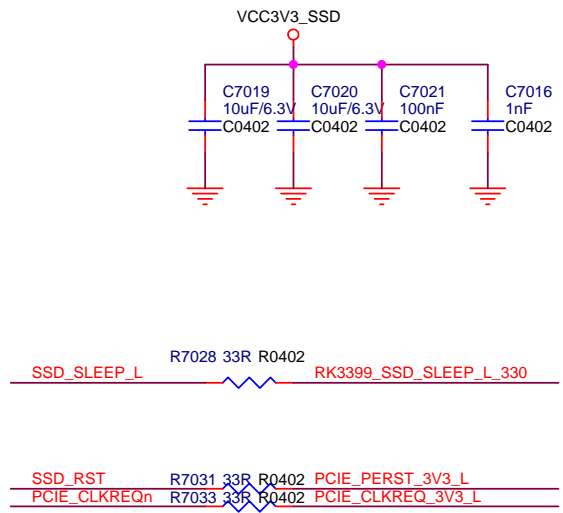
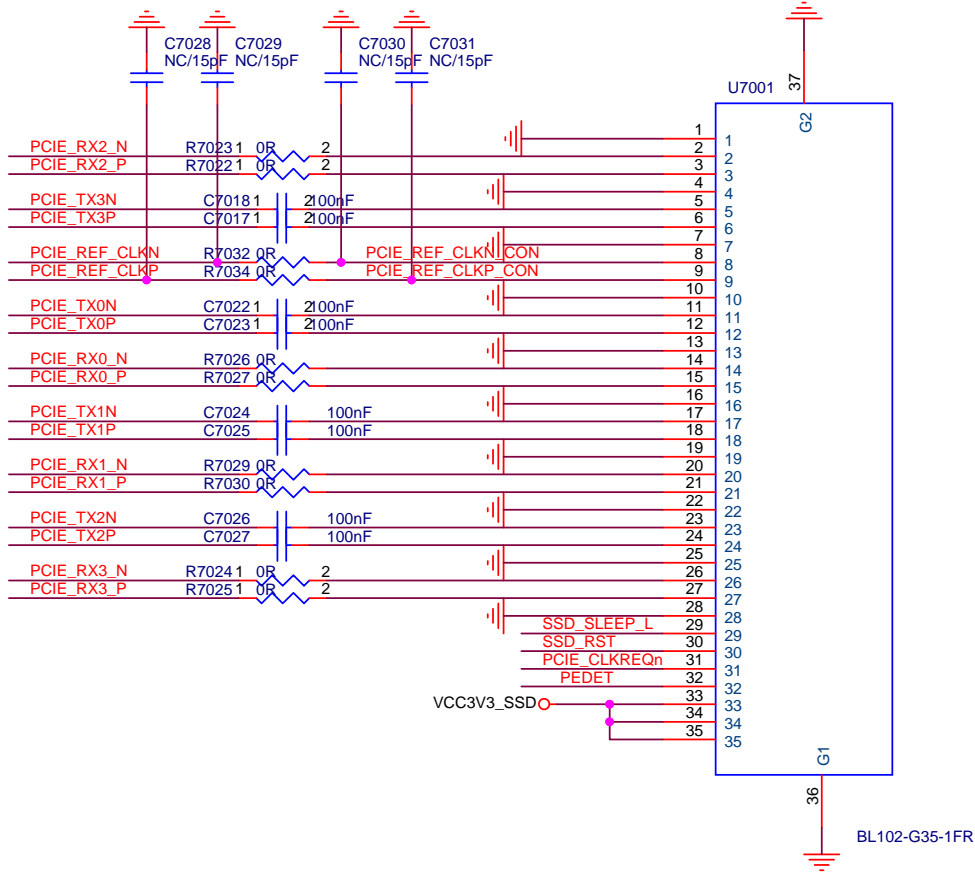

PINE64		<b>PINE64</b>	
Title Pinebook Pro			
Size Custom	Document Number SSD		Rev V2.1
Date:		Sheet 23 of 23	