

DDR3 16x2

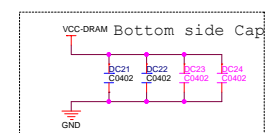

CPU

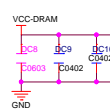
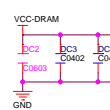
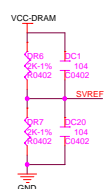
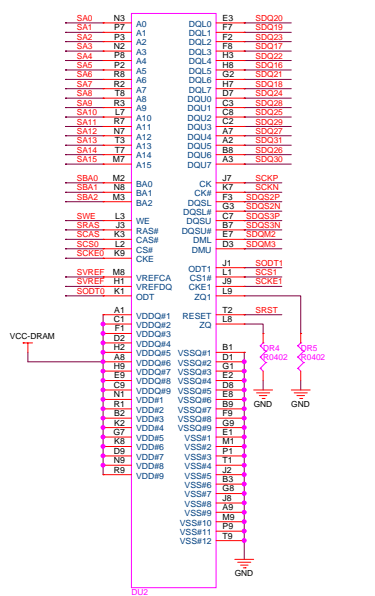
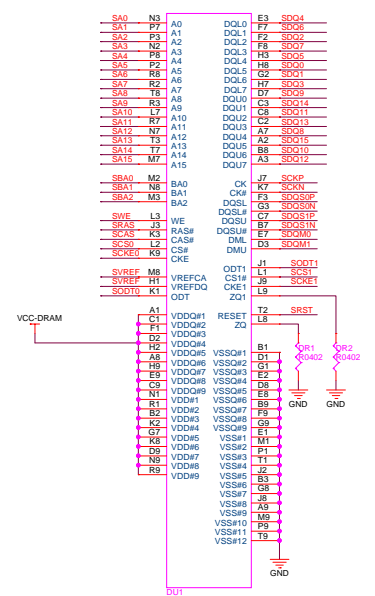
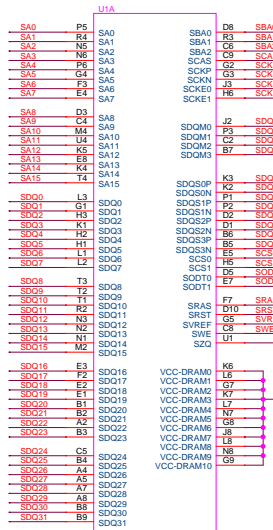
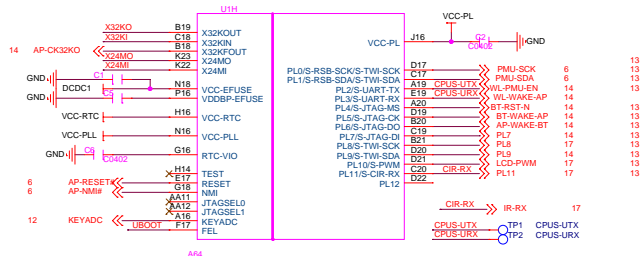

Away from the board outline and sensitive signal. Around GND line.

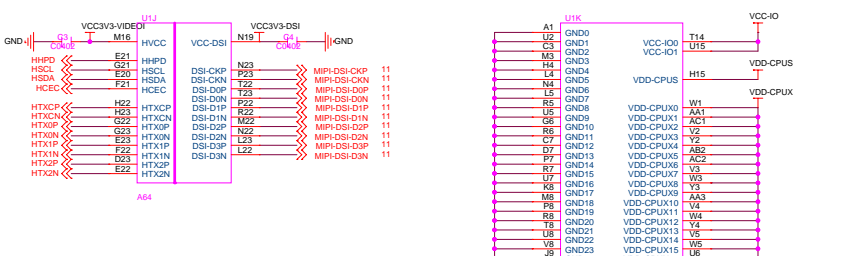
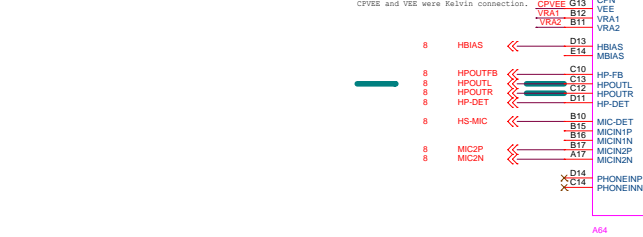
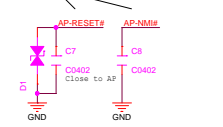

Away from the board outline and sensitive signal. Around GND line.

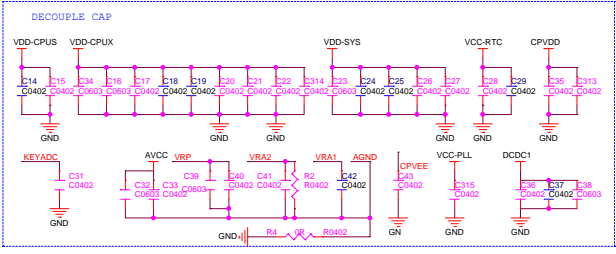
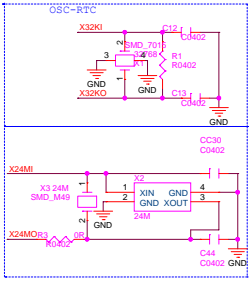
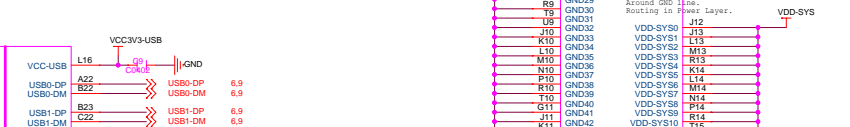

Pine A64

PMIC

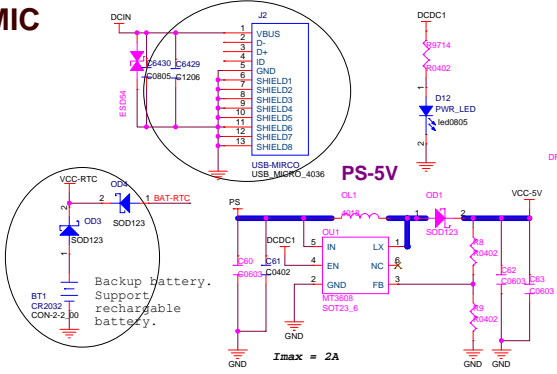

PMIC

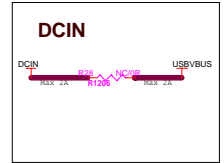
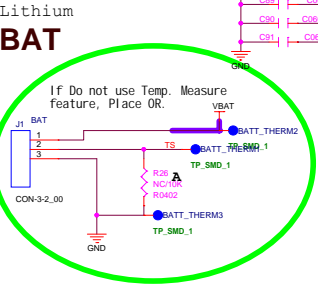
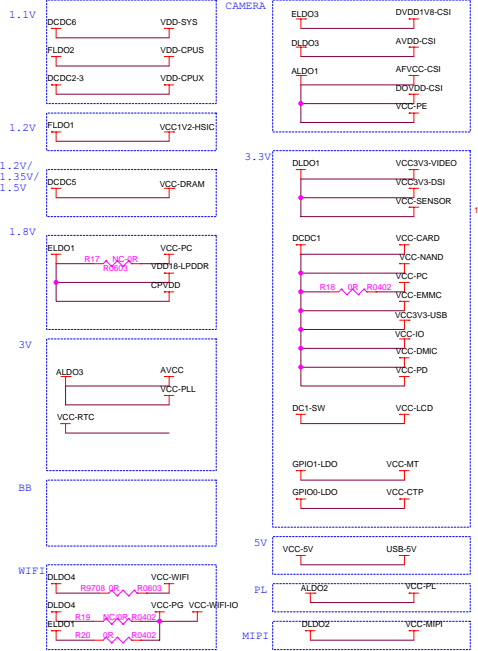
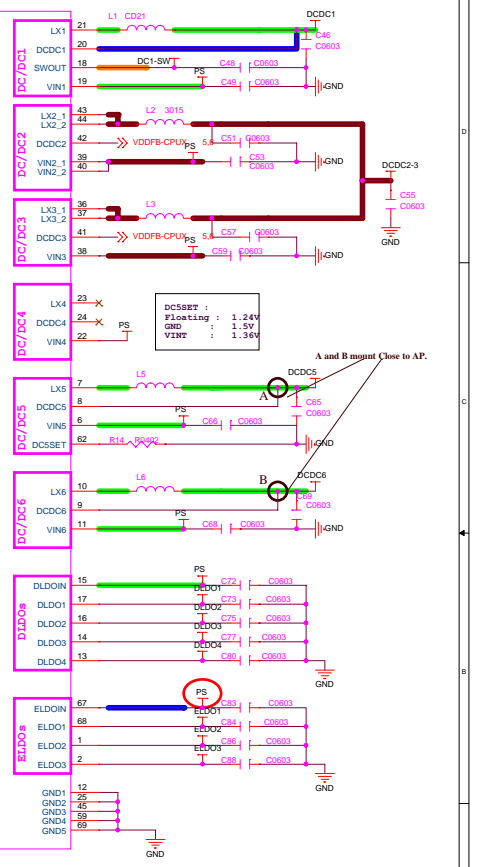
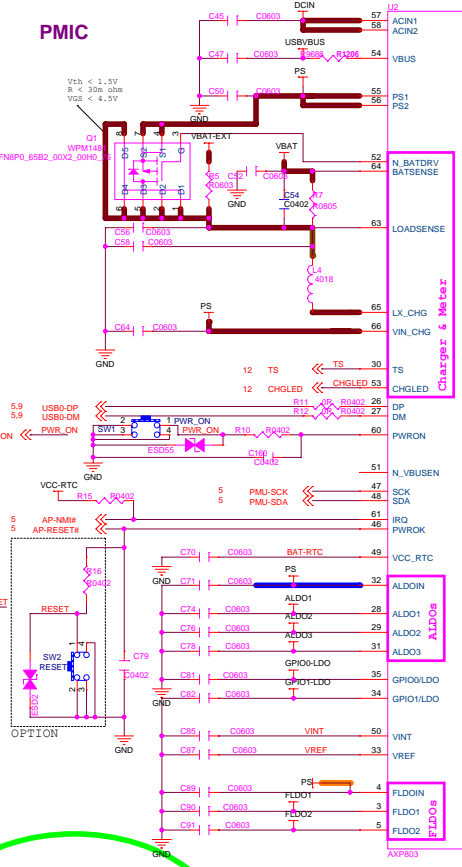

Pine A64	
A64-DB	
Title	A64-DB
Document Number	PMIC
Pg 6/19	Rev 1.2

NAND/eMMC

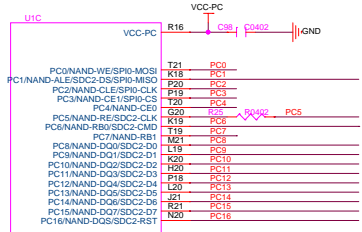

A64

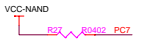
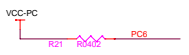
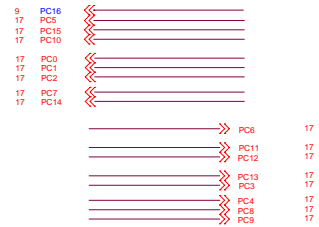

AUDIO

HP JACK

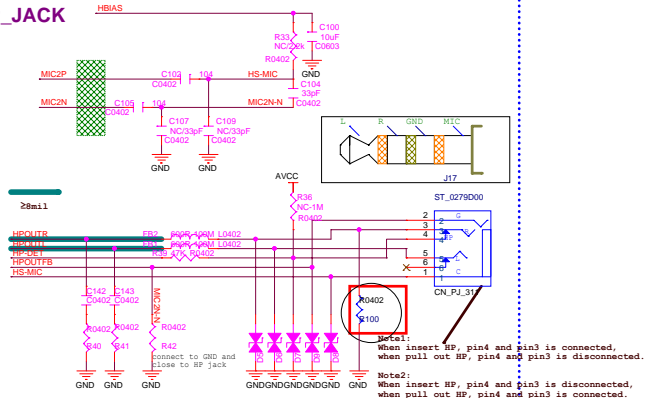

- 5 HBIAS <<< _____
- 5 HP-DET <<< _____
- 5 HP-OUTFB <<< _____
- 5 HP-OUTL <<< _____
- 5 HP-OUTR <<< _____
- 5 MIC2N <<< _____
- 5 MIC2P <<< _____
- 5 HS-MIC <<< _____

- 5 EAROUTP <<< _____
- 5 EAROUTN <<< _____

AVCC _____

VCC-5V _____

T-CARD/USB

T-CARD

SDCO-CLK TP7 UART0-TX TP_SMD_1
SDCO-D3 TP8 UART0-RX TP_SMD_1

U19

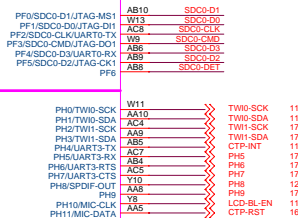

AB4

VCC-CARD

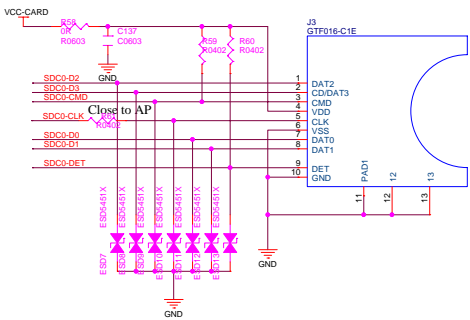

USB

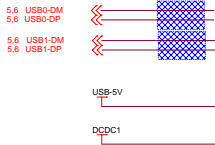
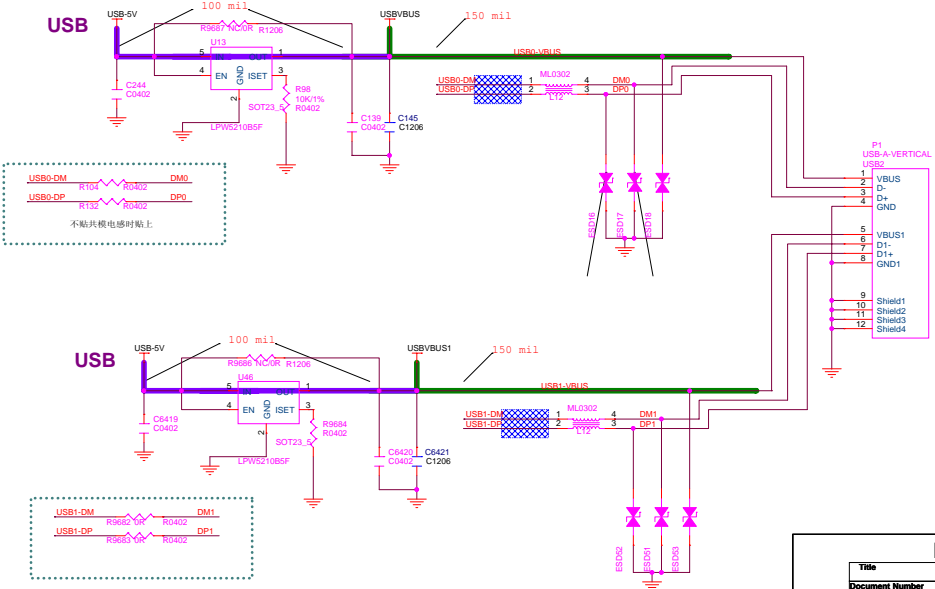

CAMERA

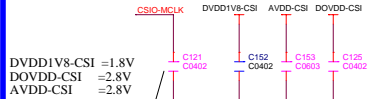
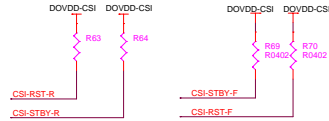

Close to camera.

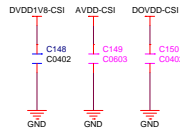

Close to AP



Close to Camera

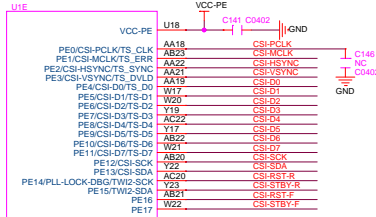

A64

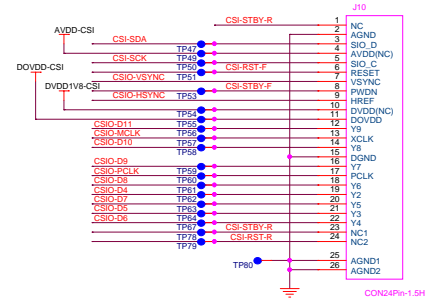
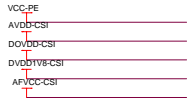

CON24Pin-1.5H

Euler Bus

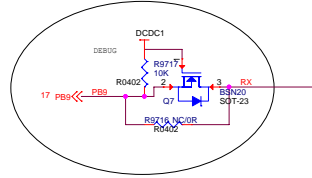
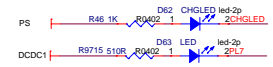
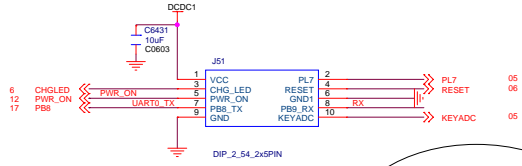
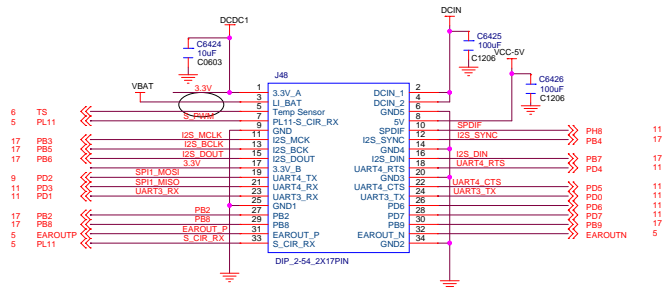

VIDEO

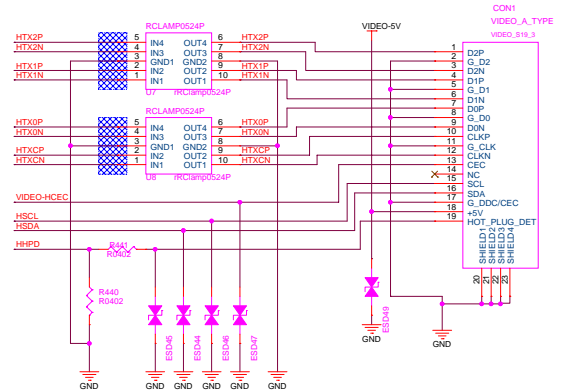
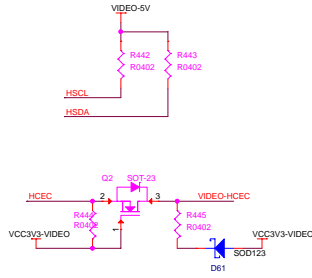
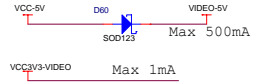

LCD POWER

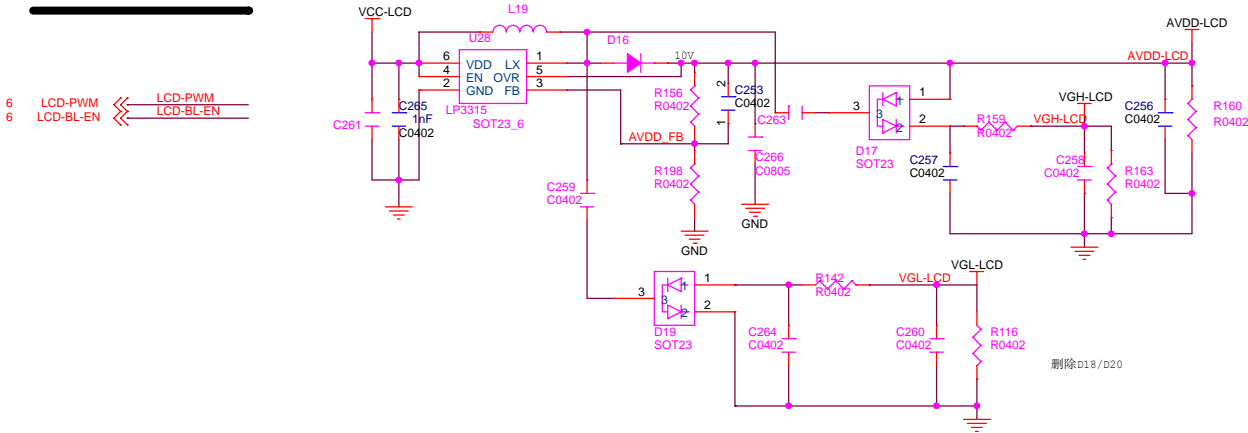

删除D18/D20

Backlight

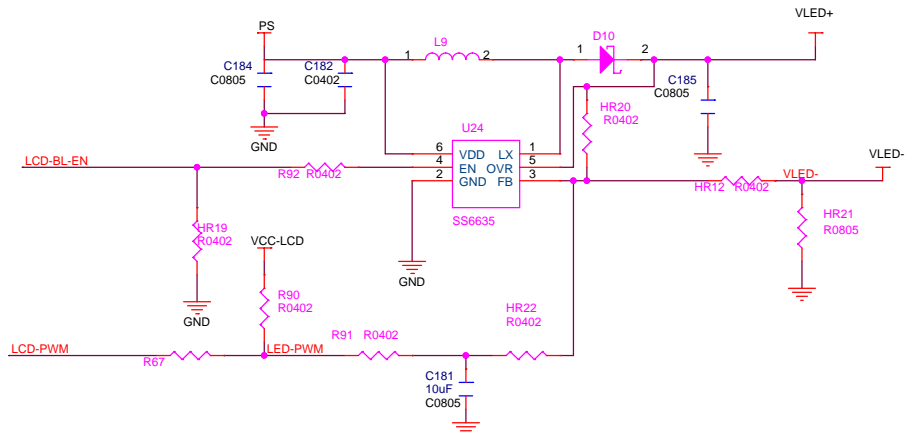

Pine A64	
A64-DB	
Document Number LCD POWER	
Pg 14/19	Rev V

WIFI+BT

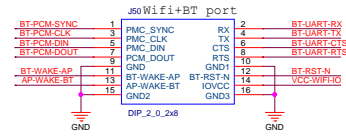
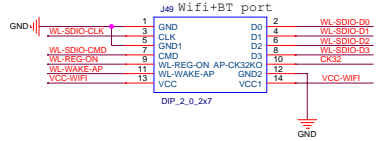
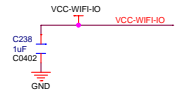
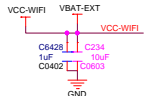
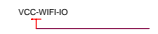
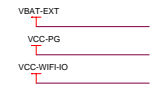
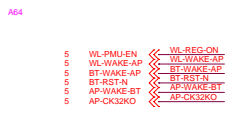
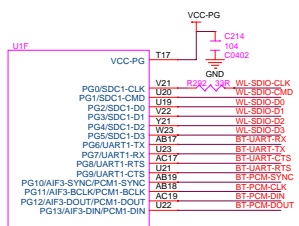

CTP/IR

IR

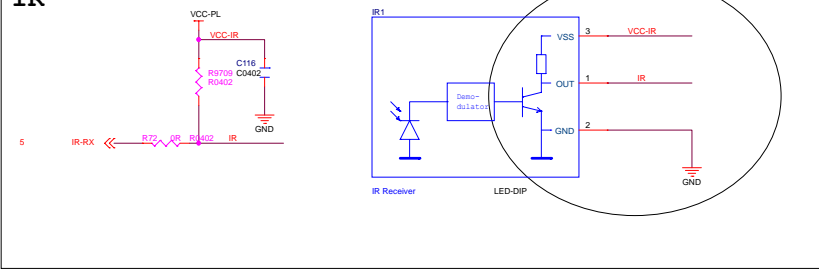

CTP

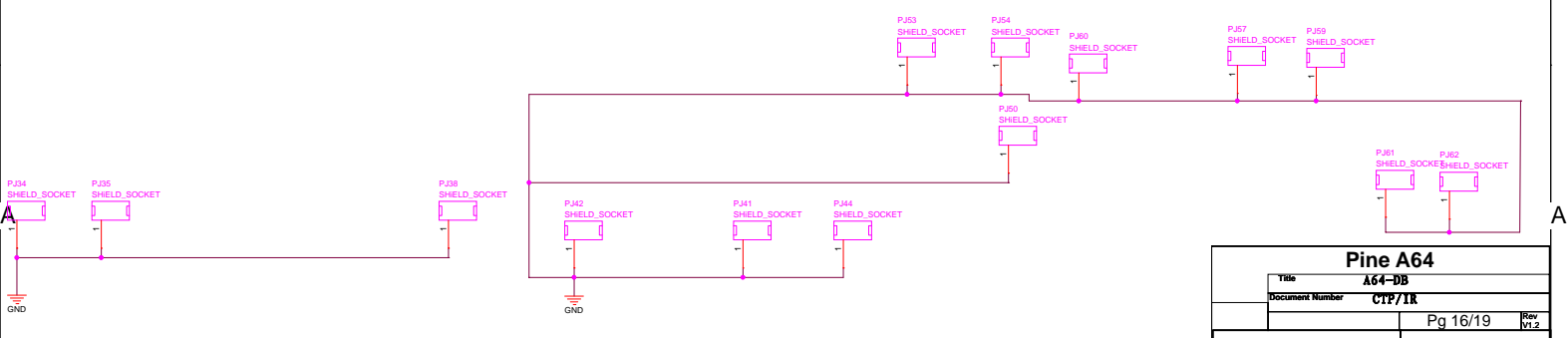
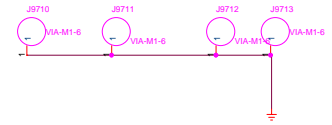
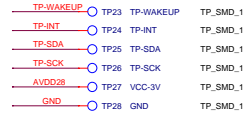
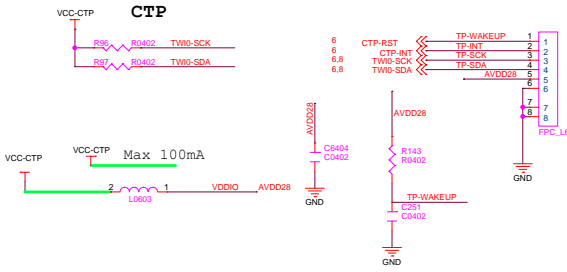

PI-2 Bus

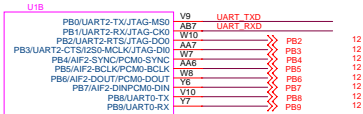

A64

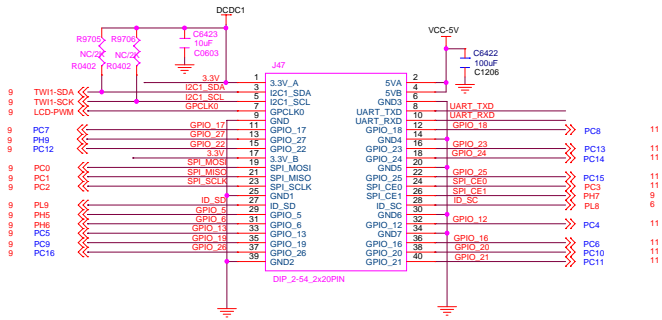

Pine A64	
Title	A64-DB
Document Number	PI-2
	Pg 17/19 Rev M1.2

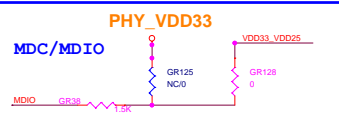
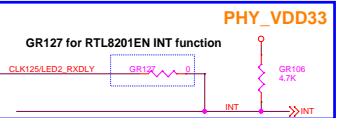
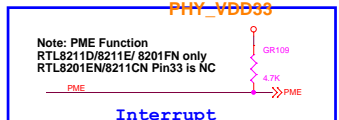

MDIO >>> MDIO RTL8201FN/EN/8211CN/8211D: GR128(NC)
MDC >>> MDC RTL8211E:GR125(NC)

Configuration Setting

MII/RMII Setting only for RTL8201FN & RTL8201EN PHYAD2
Setting only for RTL8211E

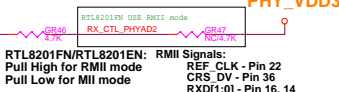

RTL8201FN/RTL8201EN: RMII Signals:
REF_CLK - Pin 22
CRS_DV - Pin 36
RXD[1:0] - Pin 16, 14
TX_EN - Pin 27
TXD[1:0] - Pin 24, 23
RX_ER - Pin 38



RTL8201FN: Pull High for LDO Enable
Pull Low for LDO disable



RTL8211D/E: If use 2.5V RGMII please pull down (GR123)RXD0/SERLGV
RTL8211CN/8201EN:GR123,GR124 NC



RTL8211CN/8211D/8211E: GR78,GR79: Config for all capability. GR71: SMI Interface GR46,GR71,R74: PHY Address=001 (8211E) GR69,GR85: Without TX/RX Delay

RTL8201EN: GR88:SMI Interface GR71,GR74: PHY Address=001 Other resistors are NC

RTL8201FN: R78: REF CLK Input R79: REF CLK Output R69,R71,R74: PHY Address=001 Other resistors are NC

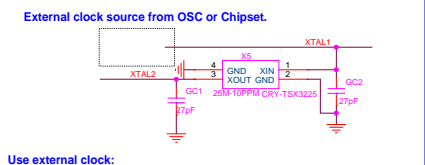

Use external clock:
RTL8201FN/RTL8201EN/8211CN/8211D/8211E: GR105(0 ohm)

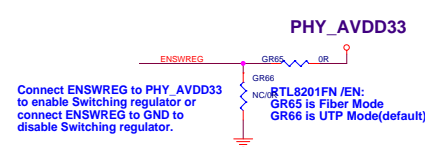

Connect ENSWREG to PHY_AVDD33 to enable Switching regulator or connect ENSWREG to GND to disable Switching regulator.

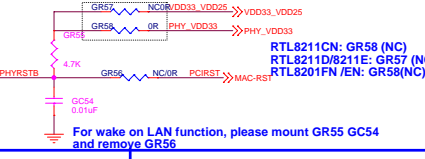

For wake on LAN function, please mount GR55 GC54 and remove GR56

RSET/ENSWREG/CLK125 Co-layout

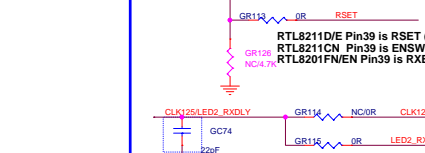

RTL8211D/E / RTL8201FN Pin32 is LED2_RXDLY (GR114 NC)
RTL8211CN Pin32 is CLK125 (GR115 NC)
RTL8201FN Pin32 is Interrupt, GR114,GR115 NC

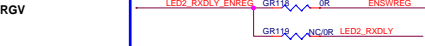

RTL8211CN Pin38 is LED2_RXDLY (GR118 NC)
RTL8211D/E Pin38 is ENSWREG (GR119 NC)
RTL8201FN Pin 38 is Collision Pin(GR118 & GR119 NC)



RTL8211D/E Pin46 is CLK125 (GR117 NC)
RTL8211CN Pin46 is RSET (GR116 NC)
RTL8201FN/EN Pin46 is RSET(GR116 NC)

Reserve for EMI.

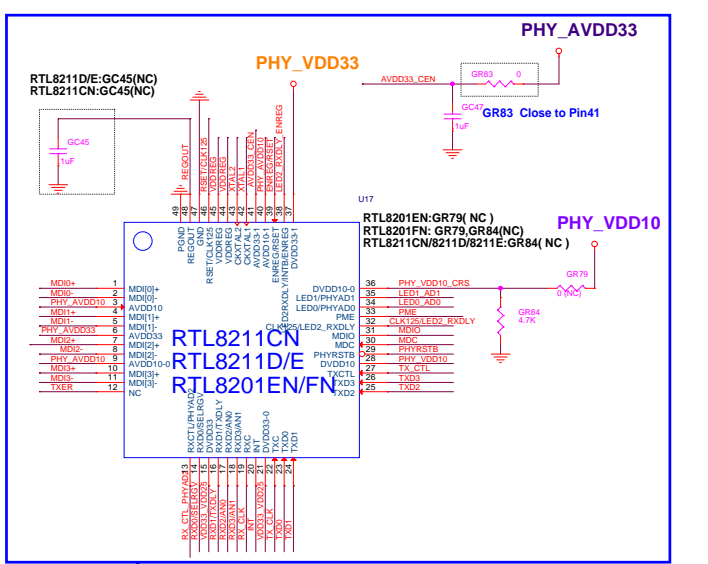

RGMII / RMII

R35,36,37 Only for RTL8201FN/EN

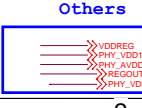
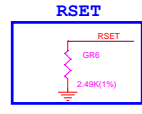
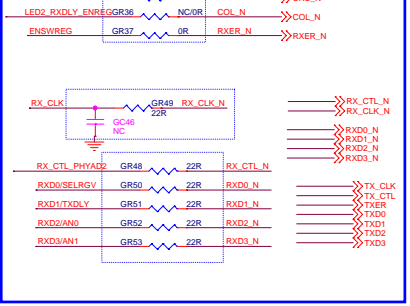

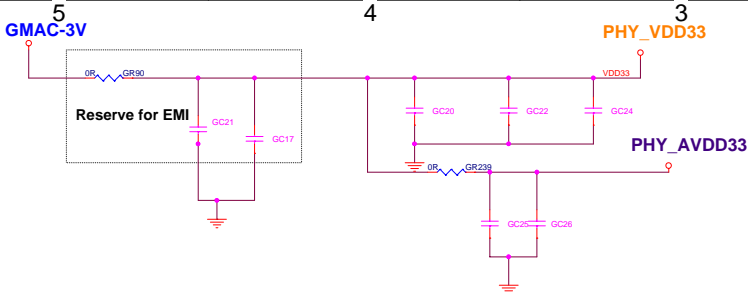

RTL8211CN/D/E	GL1	C56	U10	GR65	GR66	GR122	GC41/GC57
Enable switching regulator	○	○	✗	○	✗	✗	○
Disable switching regulator	✗	✗	○	✗	○	○	✗

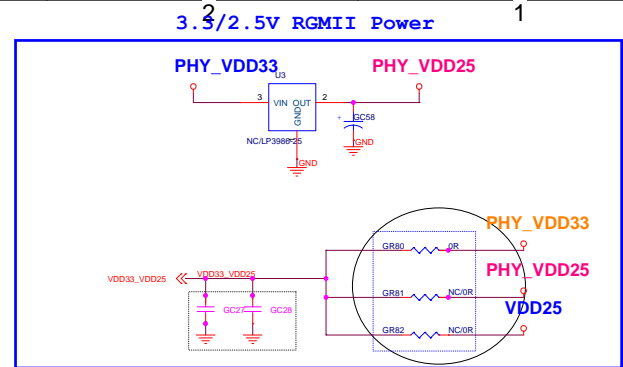

C

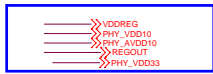
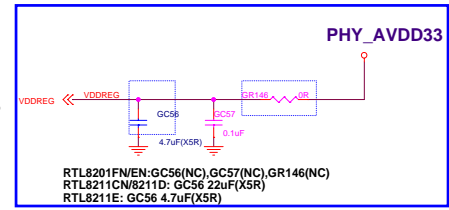
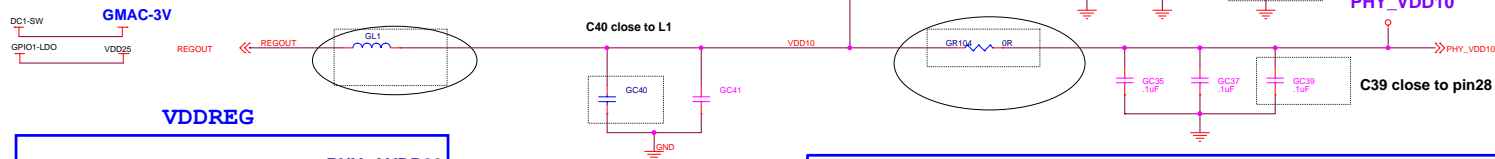

B

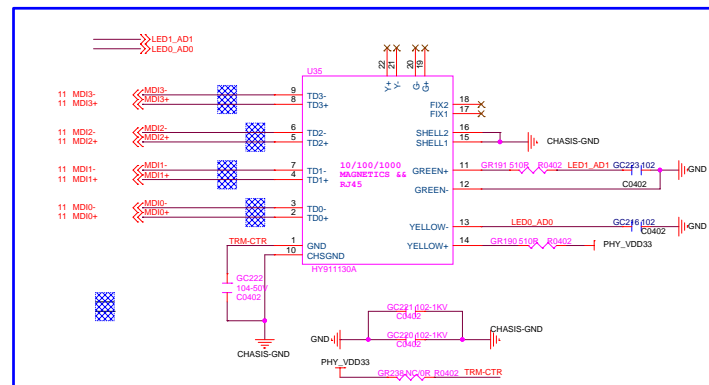

A

Pine A64			
Title	A64-DB		
Document Number	EMAC/GMAC		
	Pg 19/19	Rev	1/2