

VERSION HISTORY

Revision	Description	Date	Drawn	Checked	Approved
Ver 1.0	Release version	2015-04-22			
Ver 1.2	Added EXP Connector and rearrange Wifi/BT module pintout	2015-12-24			
	Added power LED light				

Index:

- P01: REVISION HISTORY
- P02: BLOCK DIAGRAM
- P03: POWER TREE
- P04: DDR3 16X2
- P05: CPU
- P06: PMIC
- P07: FLASH
- P08: AUDIO
- P09: USB/T-CARD
- P10: CAMERA
- P11: LCD
- P12: Euler e Connector
- P13: VIDEO
- P14: LED POWER
- P15: WIFI+BT
- P16: CTP/IR
- P17: Pi-2 Connector
- P18: EMAC/GMAC
- P19: EMAC/GMAC

Pine A64		
Title PINE A64 512MB		
Document Number VERSION HISTORY		
Size A3		Rev V1.2
Date: Wednesday, December 23, 2015	Sheet 1 of 19	

BLOCK DIAGRAM

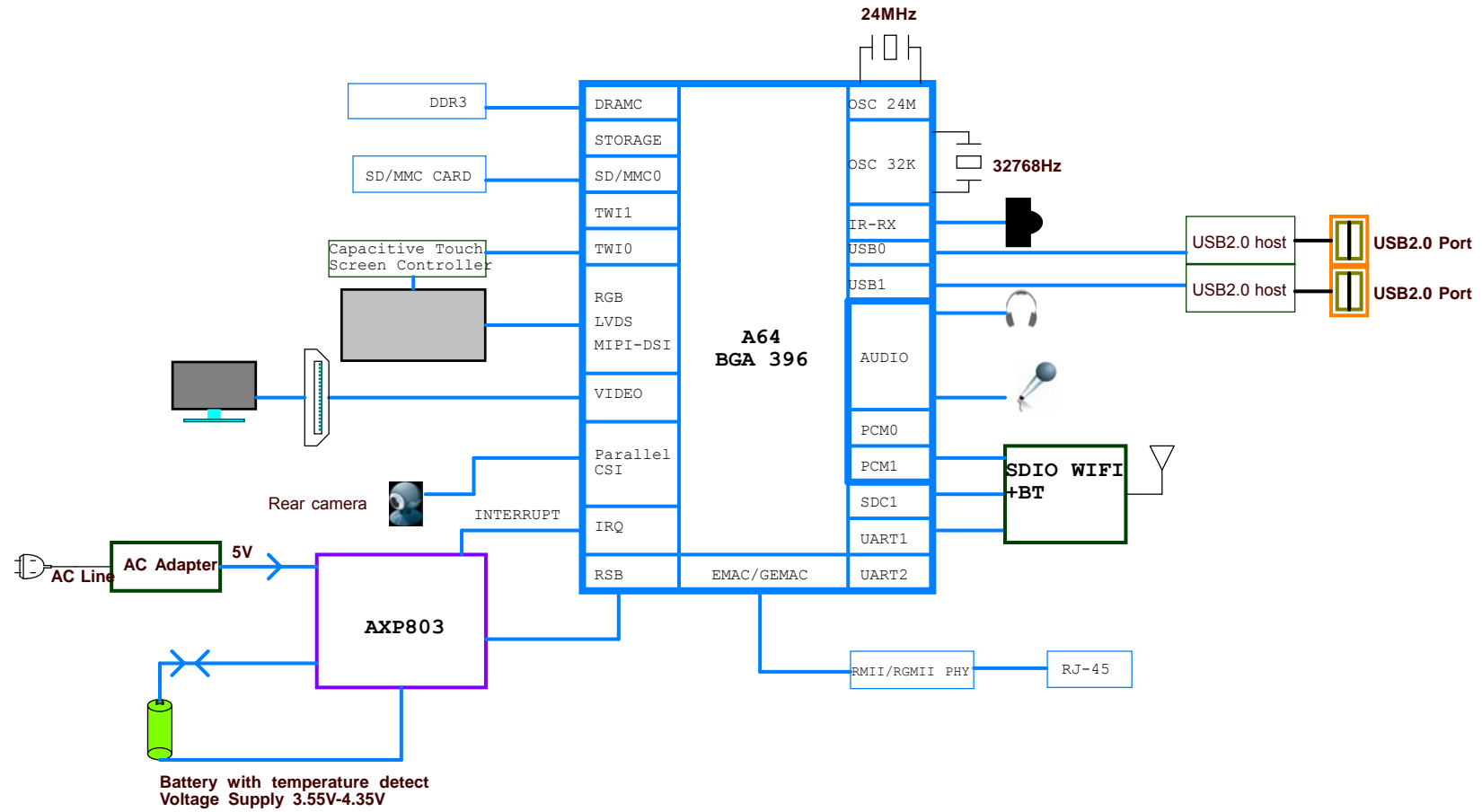

POWER TREE

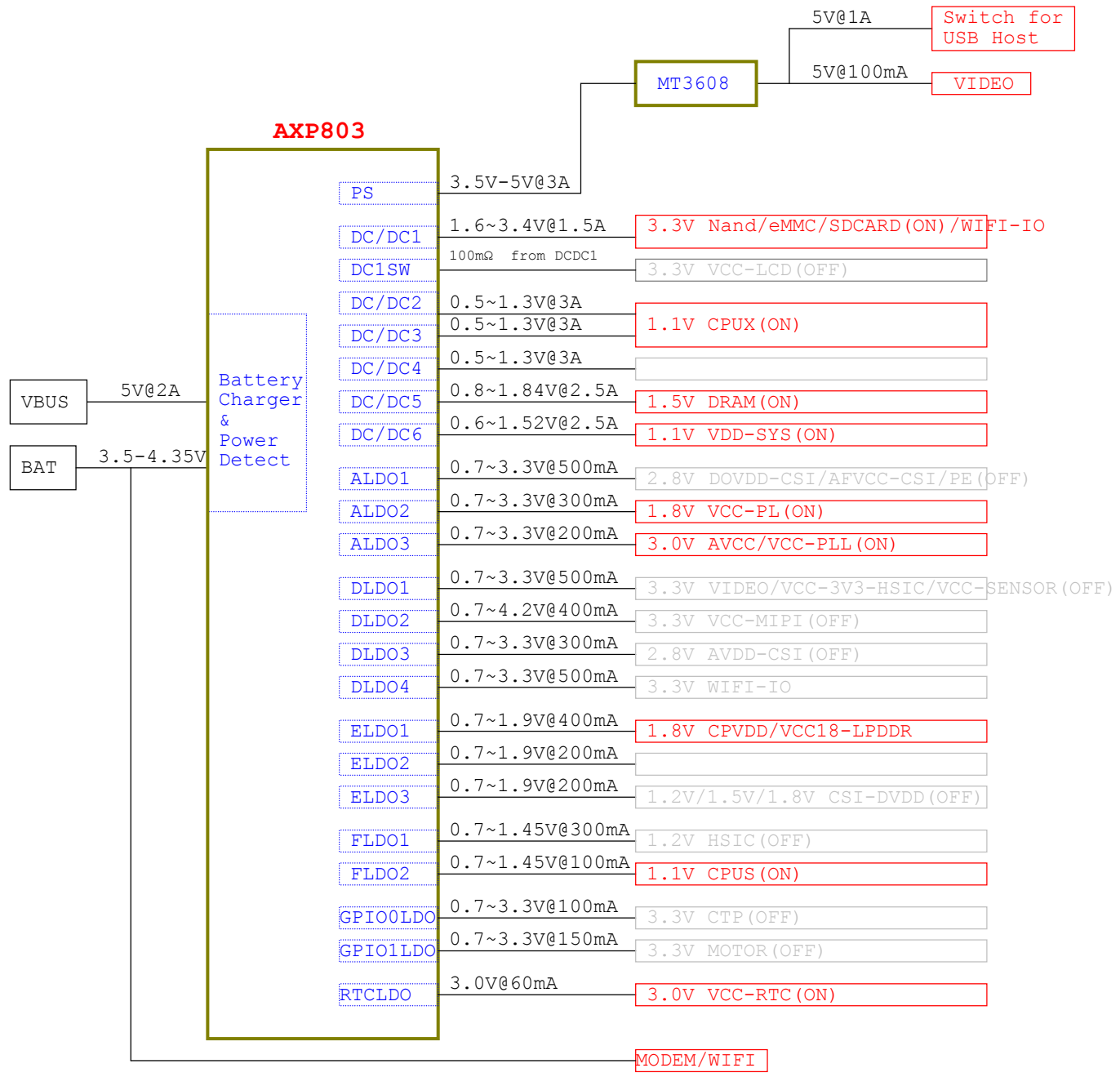

DDR3 16x2

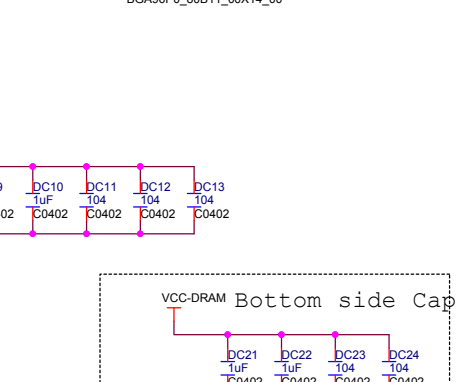
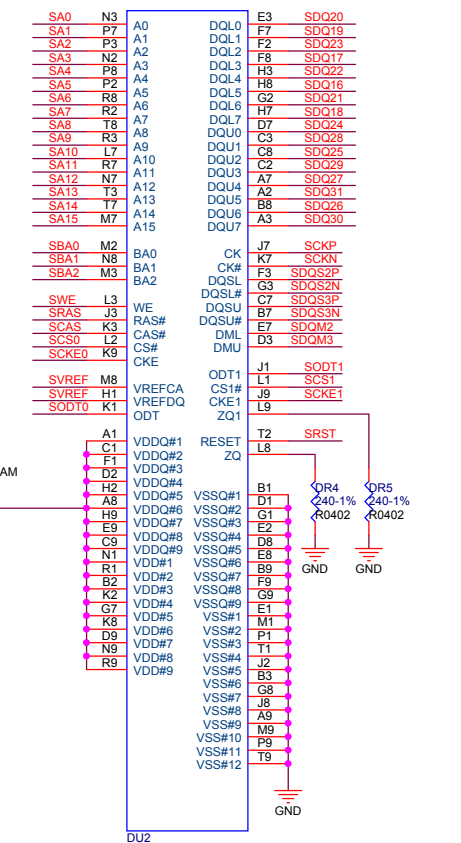
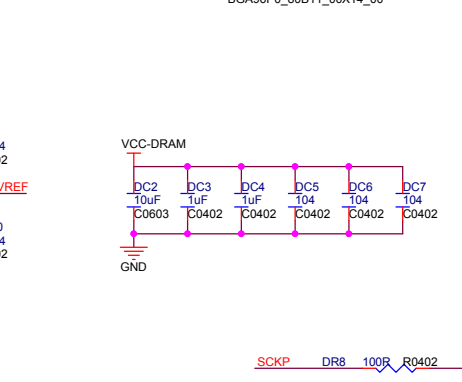
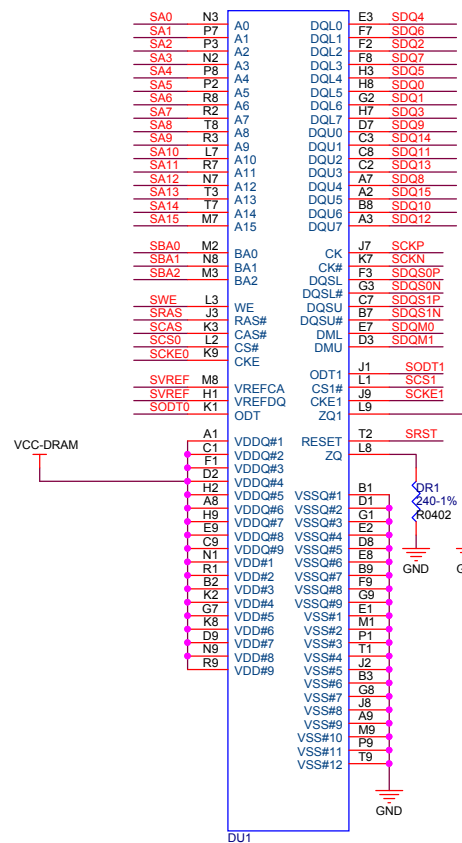
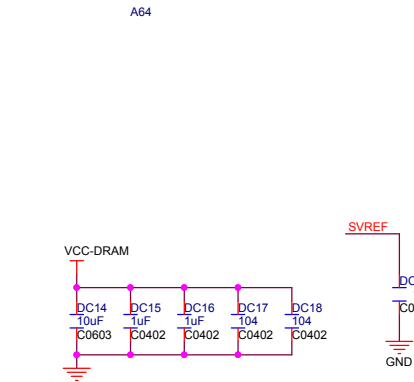
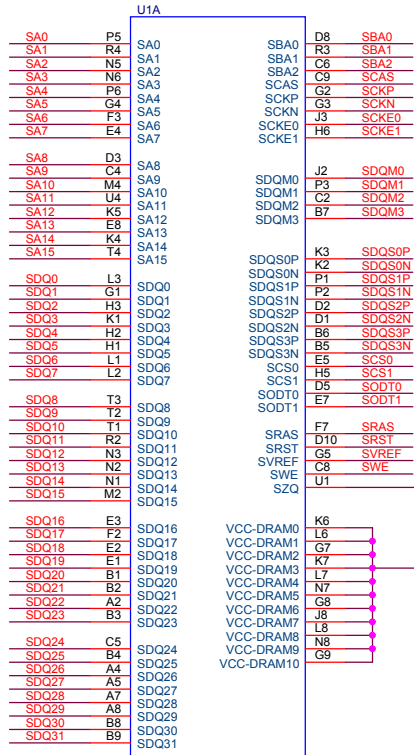

CPU

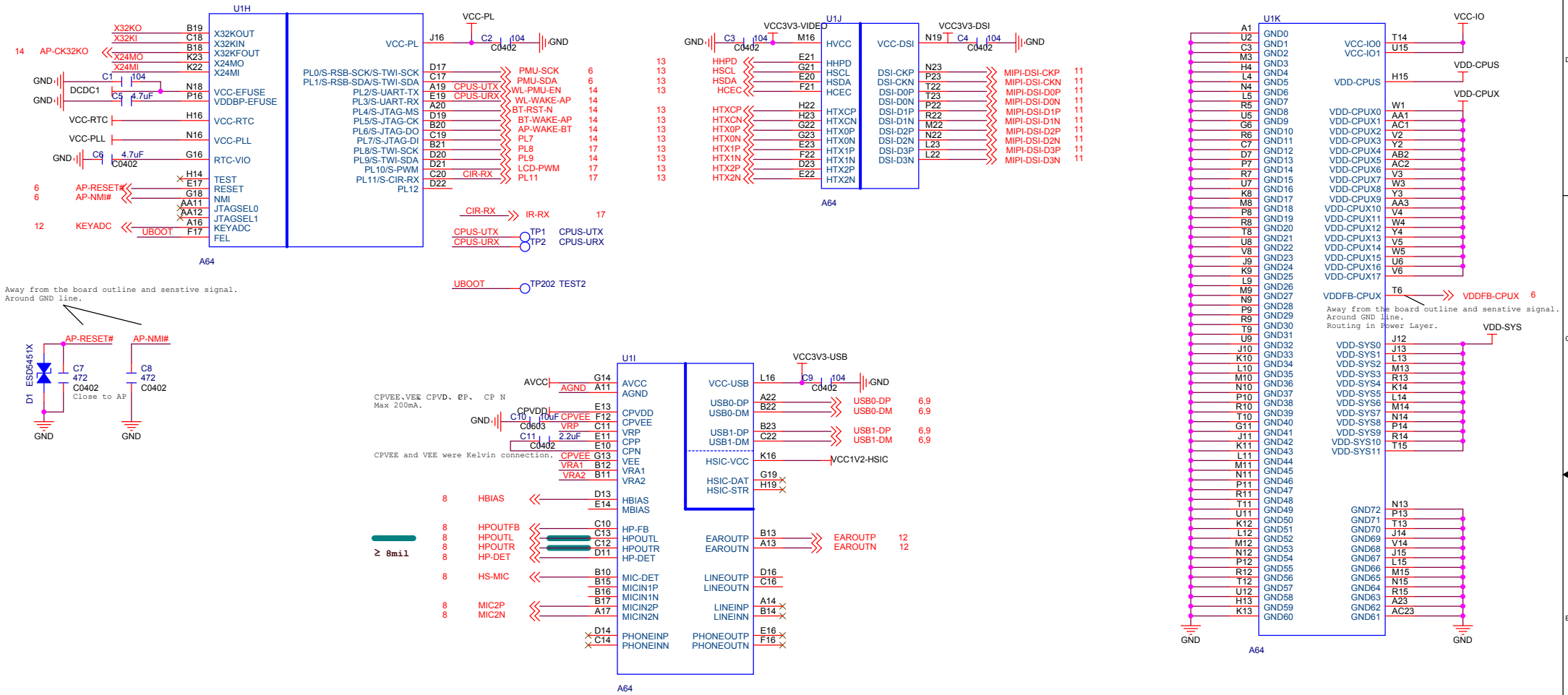

Away from the board outline and sensitive signal. Around GND line.

Away from the board outline and sensitive signal. Around GND line. Routing in Power Layer.

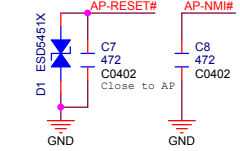

Close to AP

≥ 8mil

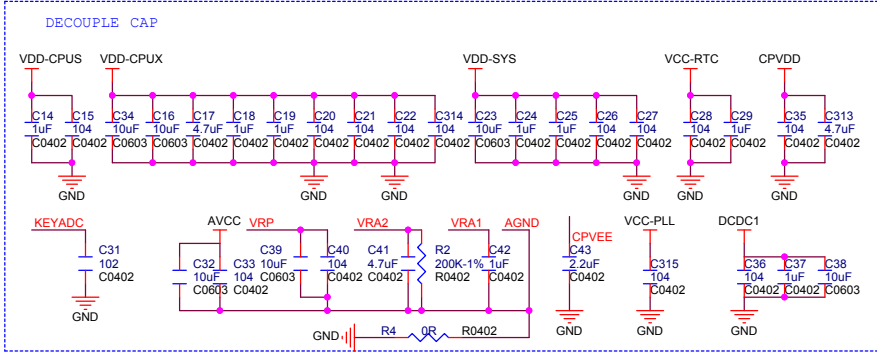
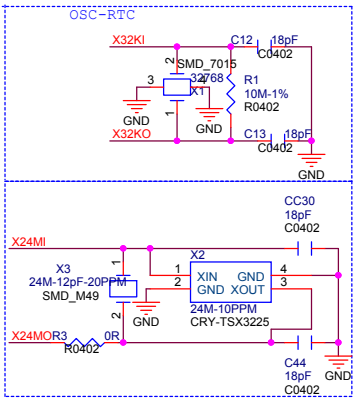

Pine A64			
Title		PINE A64 512MB	
Document Number		CPU	
Size	A3	Date:	Wednesday, December 23, 2015
Sheet	5	of	19
Rev	V1.2		

Power

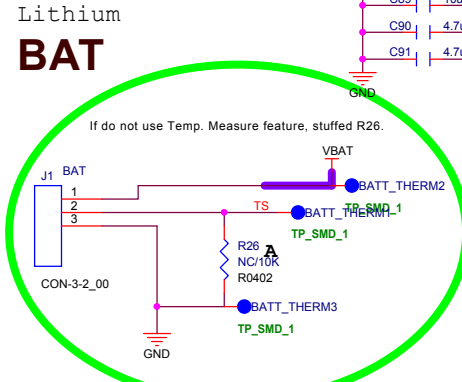
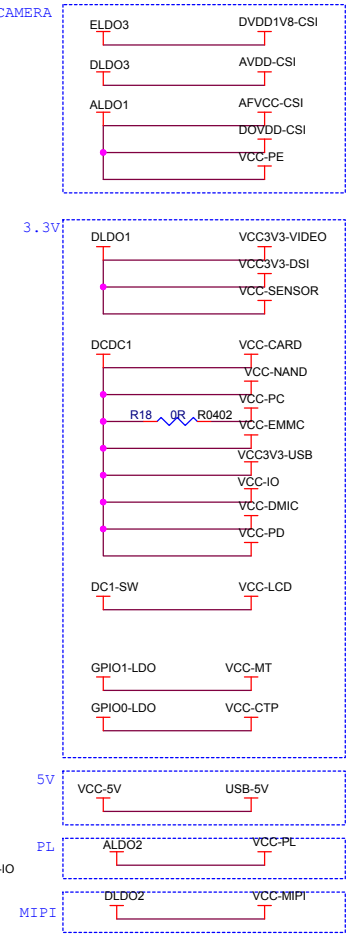
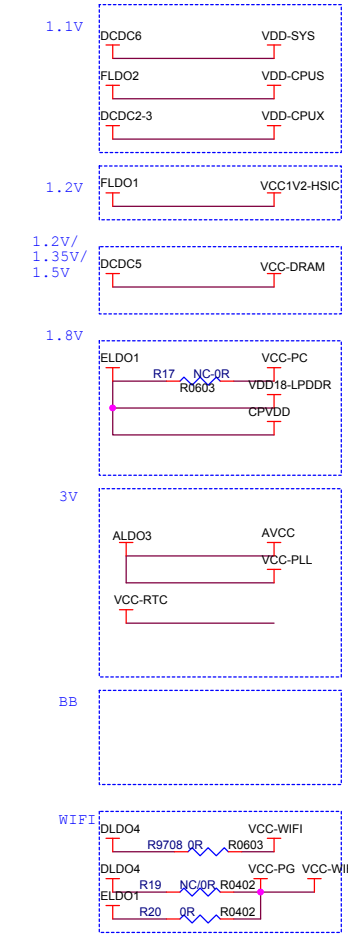
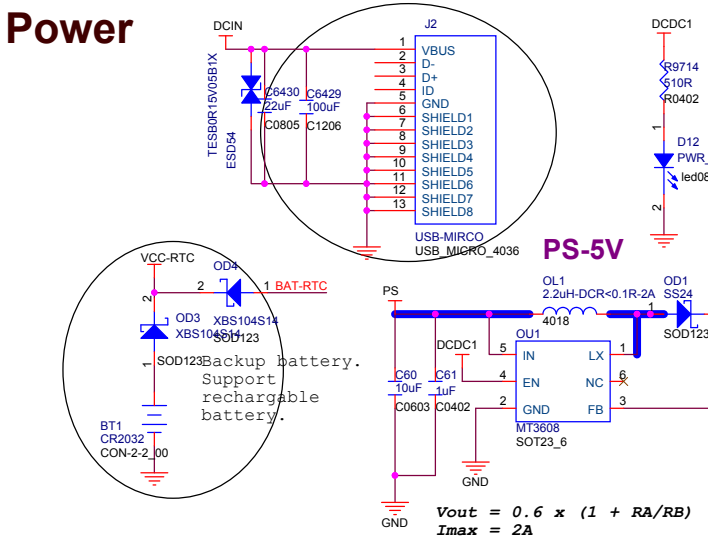

PMIC

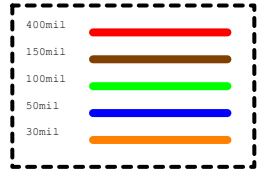
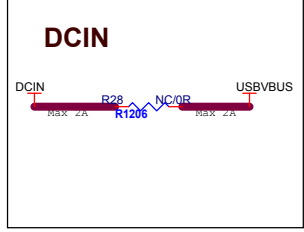
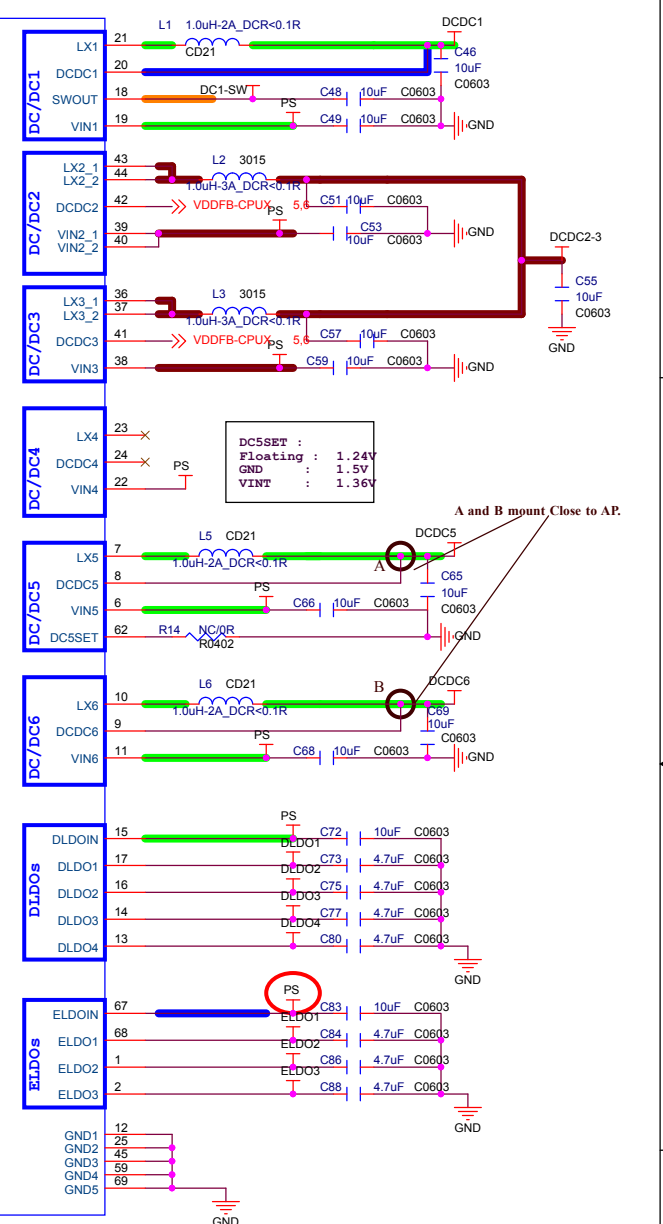
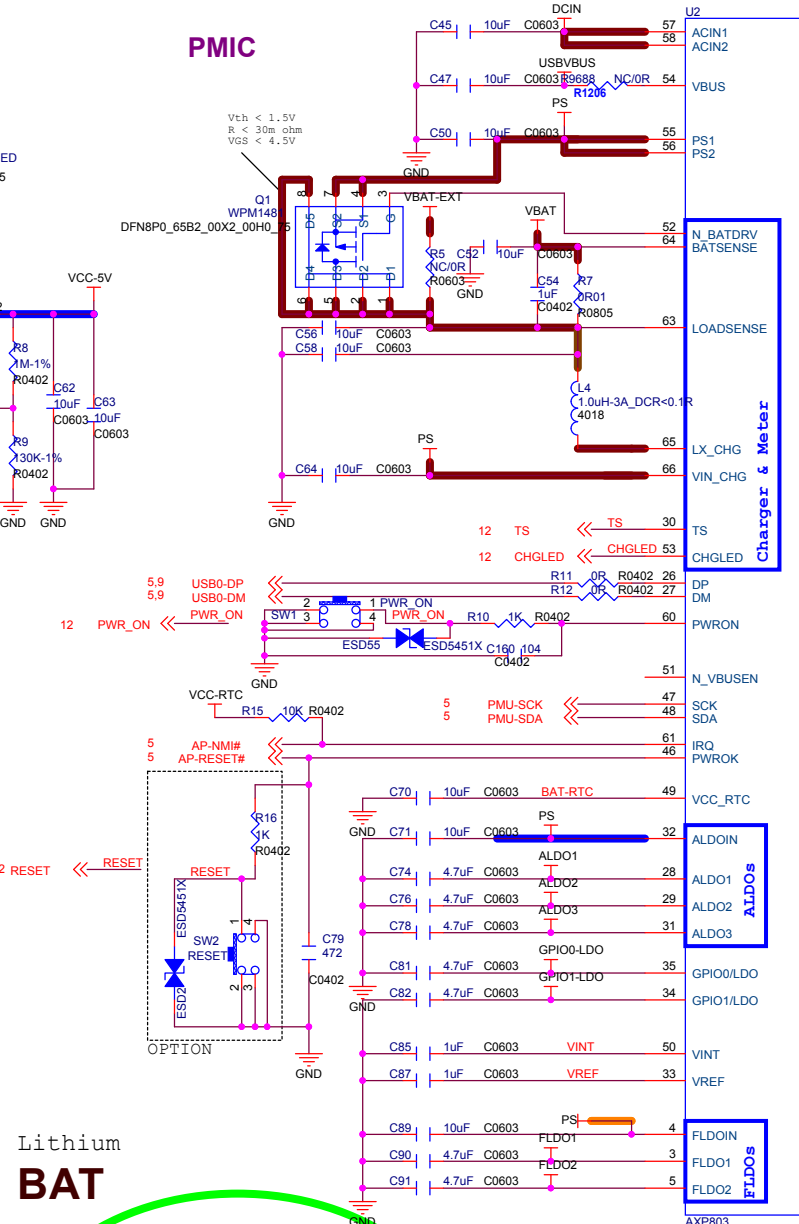

Pine A64			
Title	PINE A64 512MB		
Document Number	POWER		
Size	A3	Date	Wednesday, December 23, 2015
Sheet	6	of	19
Rev	V1.2		

NAND/eMMC

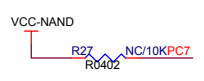
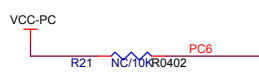
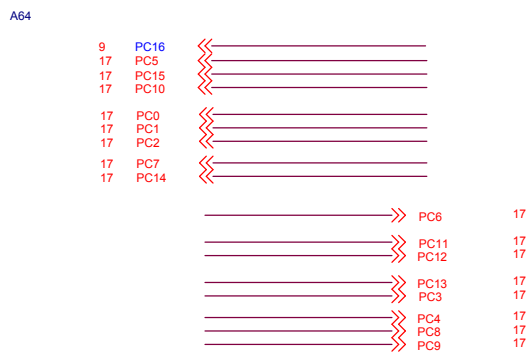
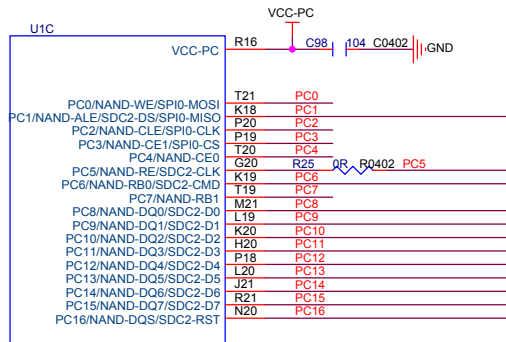

AUDIO

HP_JACK

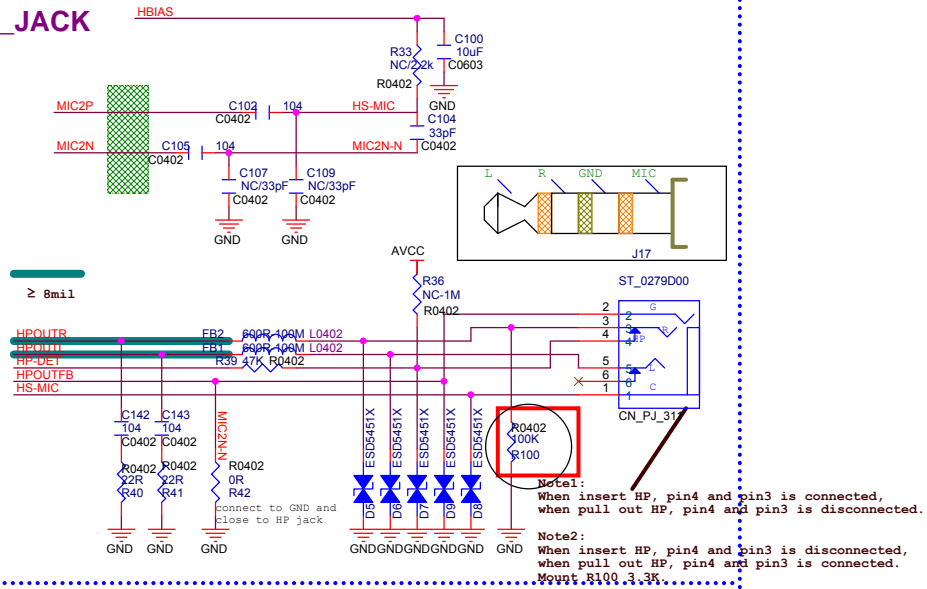

- 5 HBIAS << _____
- 5 HP-DET << _____
- 5 HPOUTLFB << _____
- 5 HPOUTL << _____
- 5 HPOUTR << _____
- 5 MIC2N << _____
- 5 MIC2P << _____
- 5 HS-MIC << _____

- 5 EAROUTP << _____
- 5 EAROUTN << _____

AVCC _____

VCC-5V _____

<i>Pine A64</i>	
Title	PINE A64 512MB
Document Number	AUDIO
Size	A3
Date:	Wednesday, December 23, 2015
Sheet	8 of 19
Rev	V1.2

T-CADD/USB

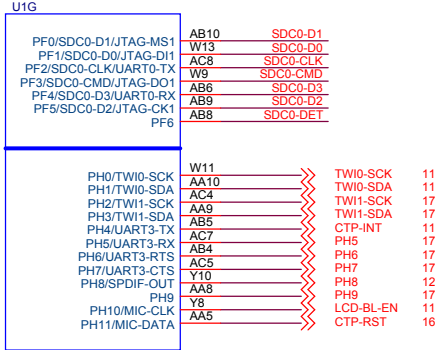

A64

VCC-CARD

T-CARD

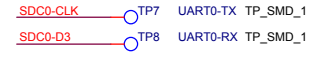
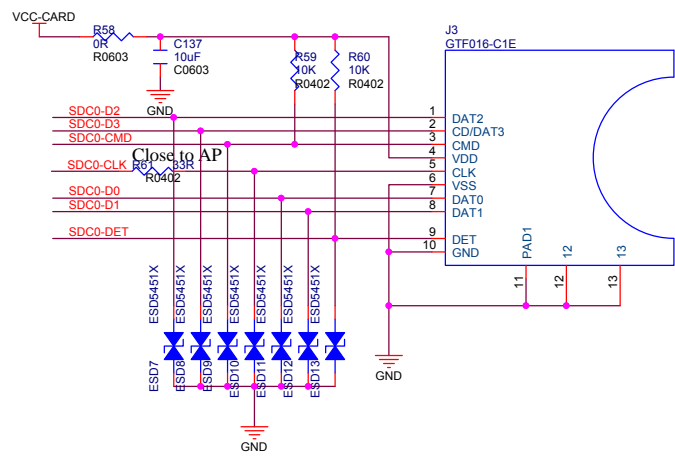

USB

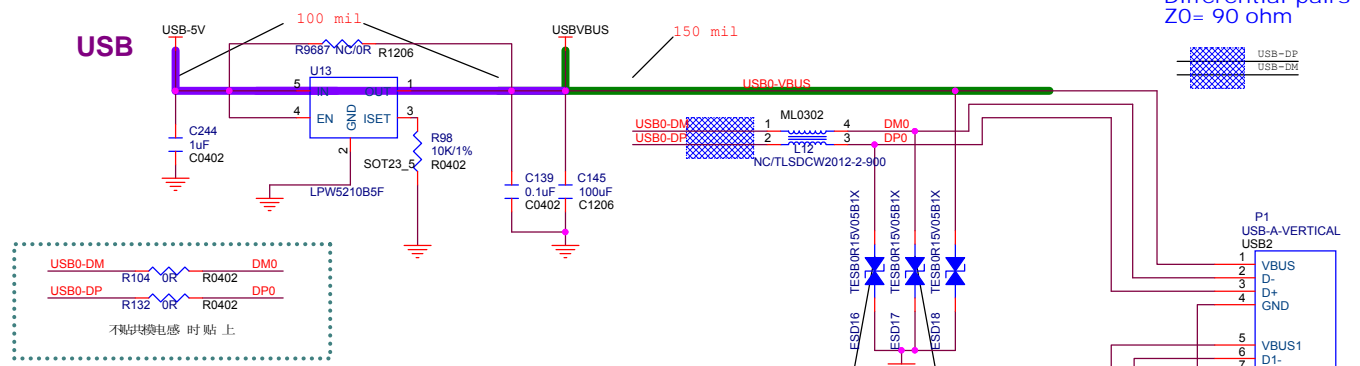

Differential pairs
ZO= 90 ohm

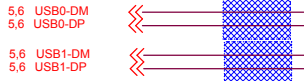
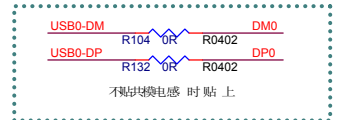

USB

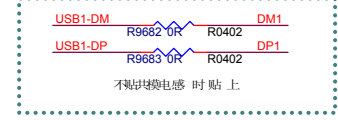
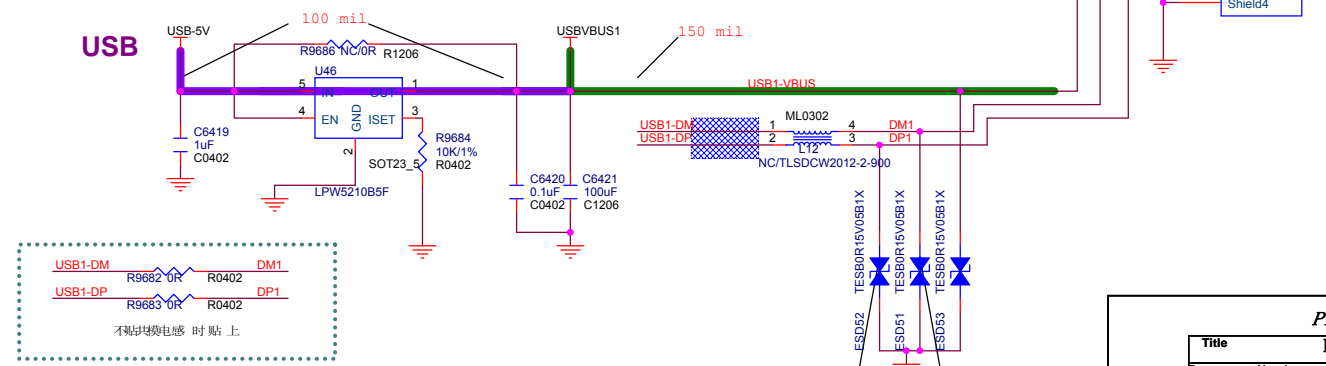

Pine A64			
Title		PINE A64 512MB	
Document Number		T-CARD/USB	
Size	A3	Date	Wednesday, December 23, 2015
		Sheet	9 of 19
		Rev	1.2

The ESD part's parasitic capacitance < 5pF.

CAM9R5

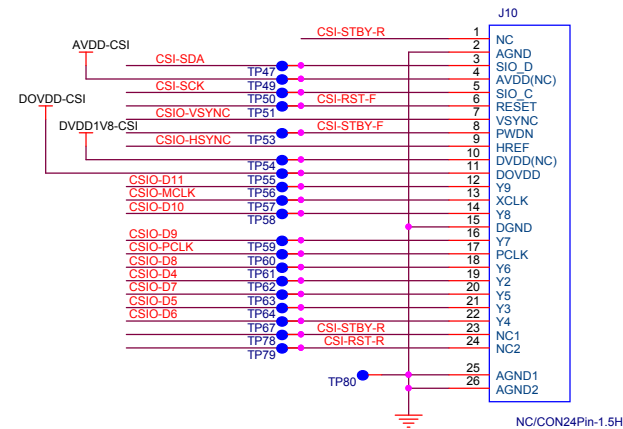
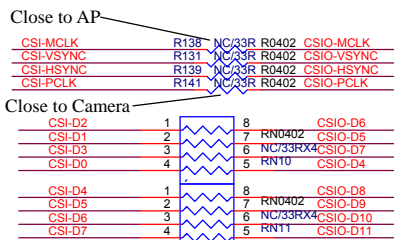
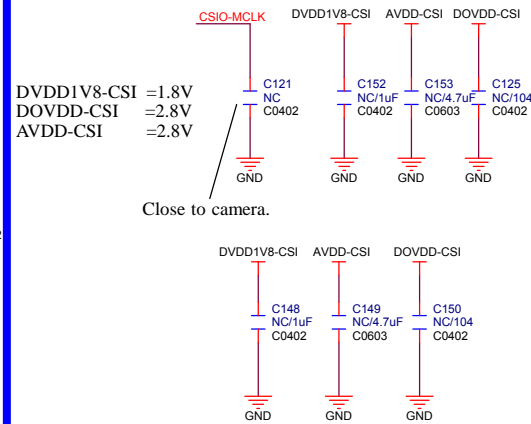
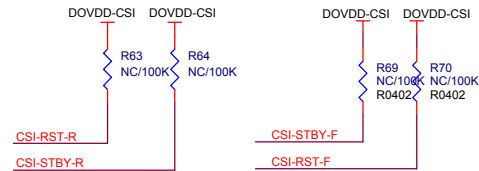
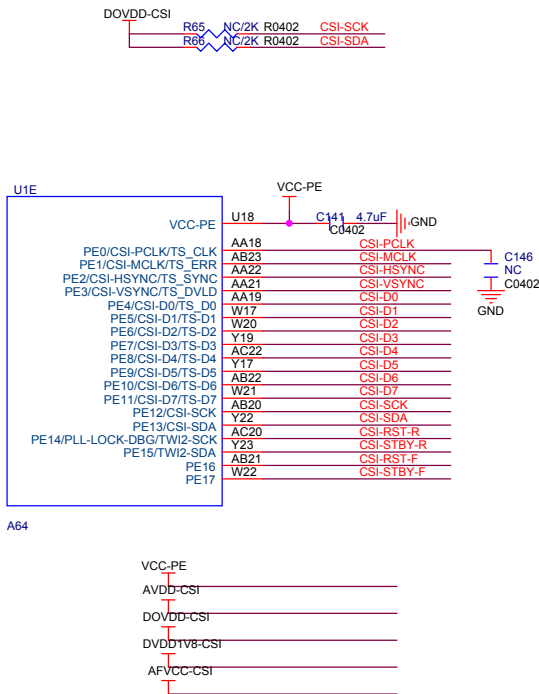

LCD

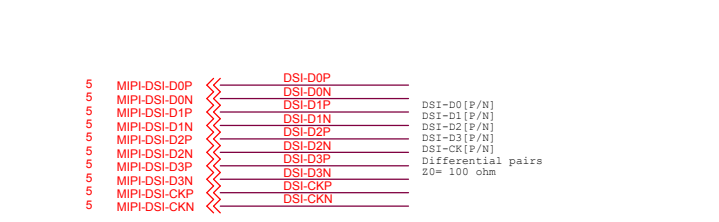
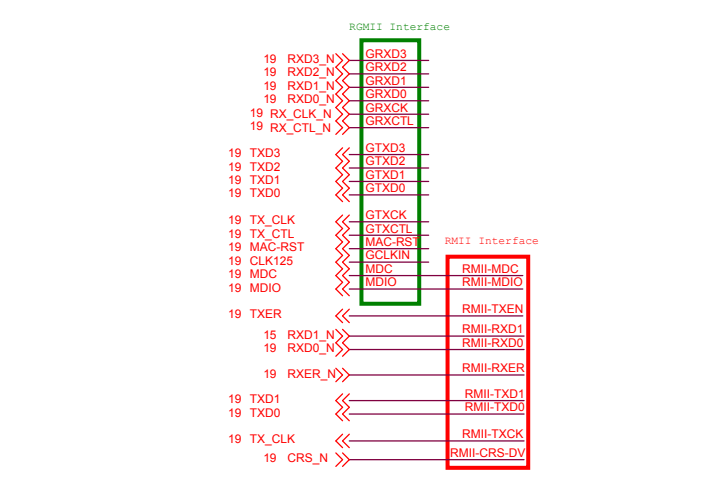
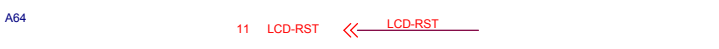
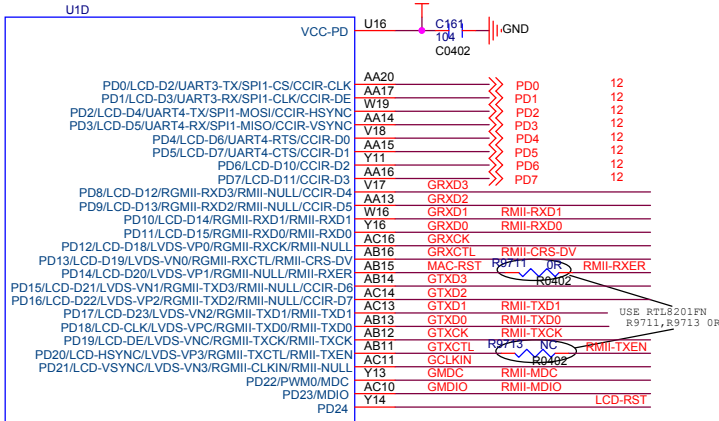

MIPI-LCD

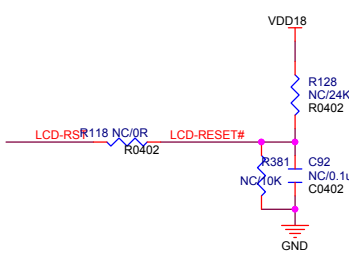
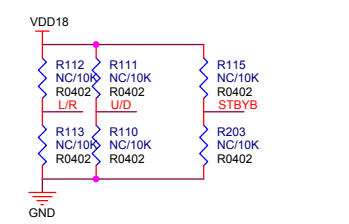
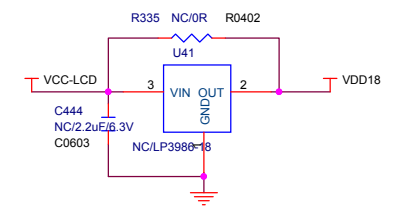
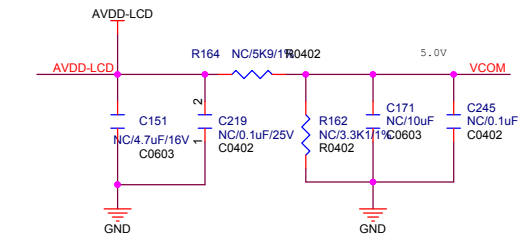

HSD 10V/3.7V CPT Vcom=4.3V

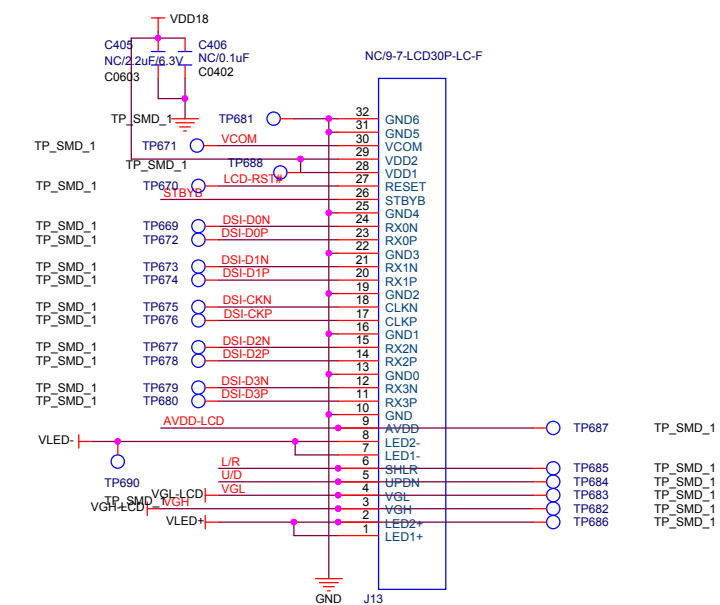
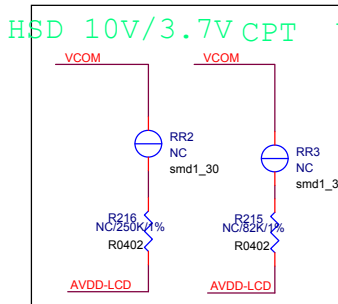

Pine A64			
Title		PINE A64 512MB	
Document Number		MIPI-LCD	
Size	A3	Rev	V1.2
Date:	Thursday, December 24, 2015	Sheet	11 of 19

Euler bus

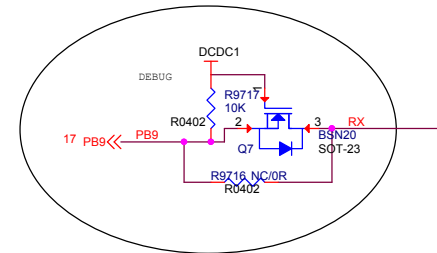
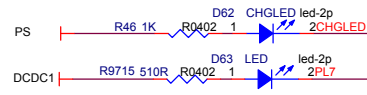
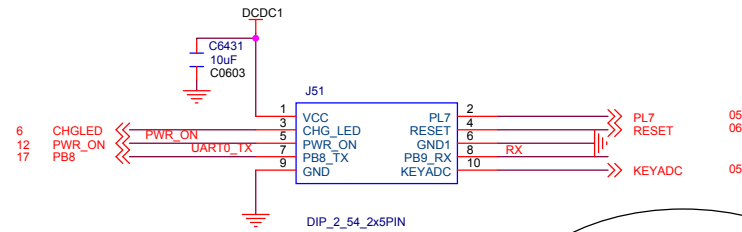
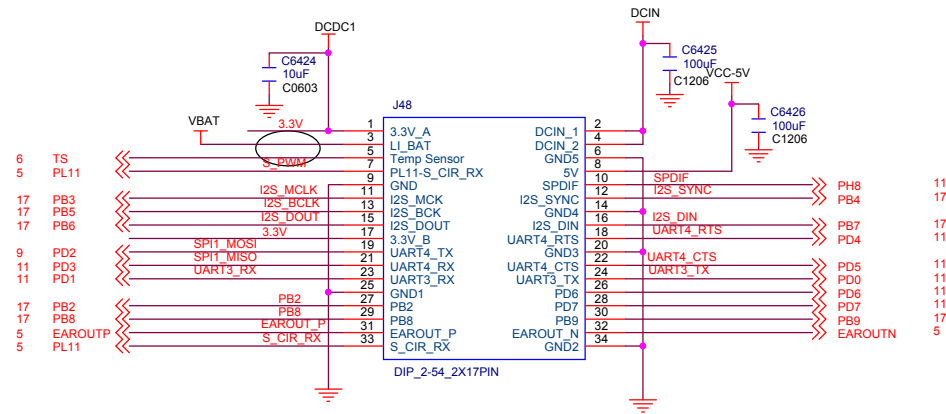

<i>Pine A64</i>	
Title	PINE A64 512MB
Document Number	EULER
Size	A3
Date:	Wednesday, December 23, 2015
Sheet	12 of 19
Rev	V1.2

Video

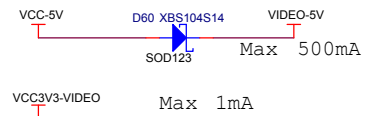

Differential pairs
Z0= 100 ohm

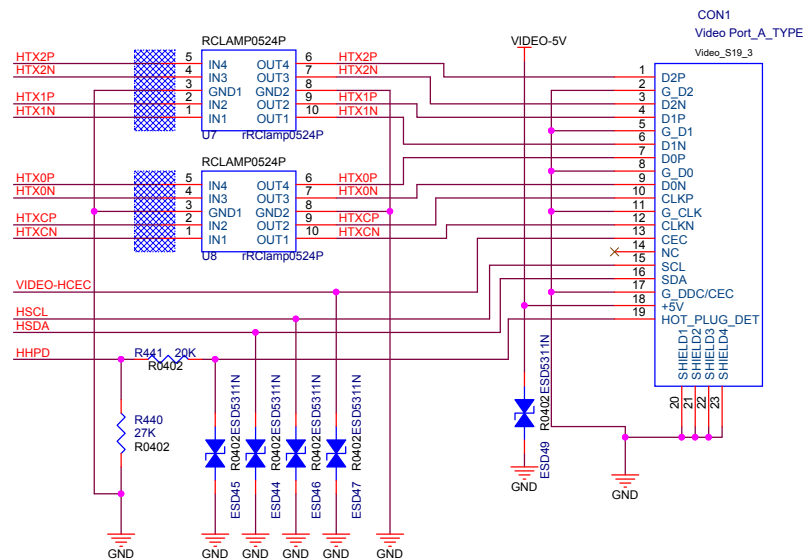
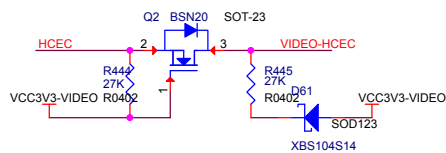
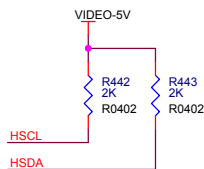

Pine A64			
Title		PINE A64 512MB	
Document Number		Video	
Size	A3	Date:	Wednesday, December 23, 2015
Sheet	13	of	19
Rev	V1.2		

LCD POWER

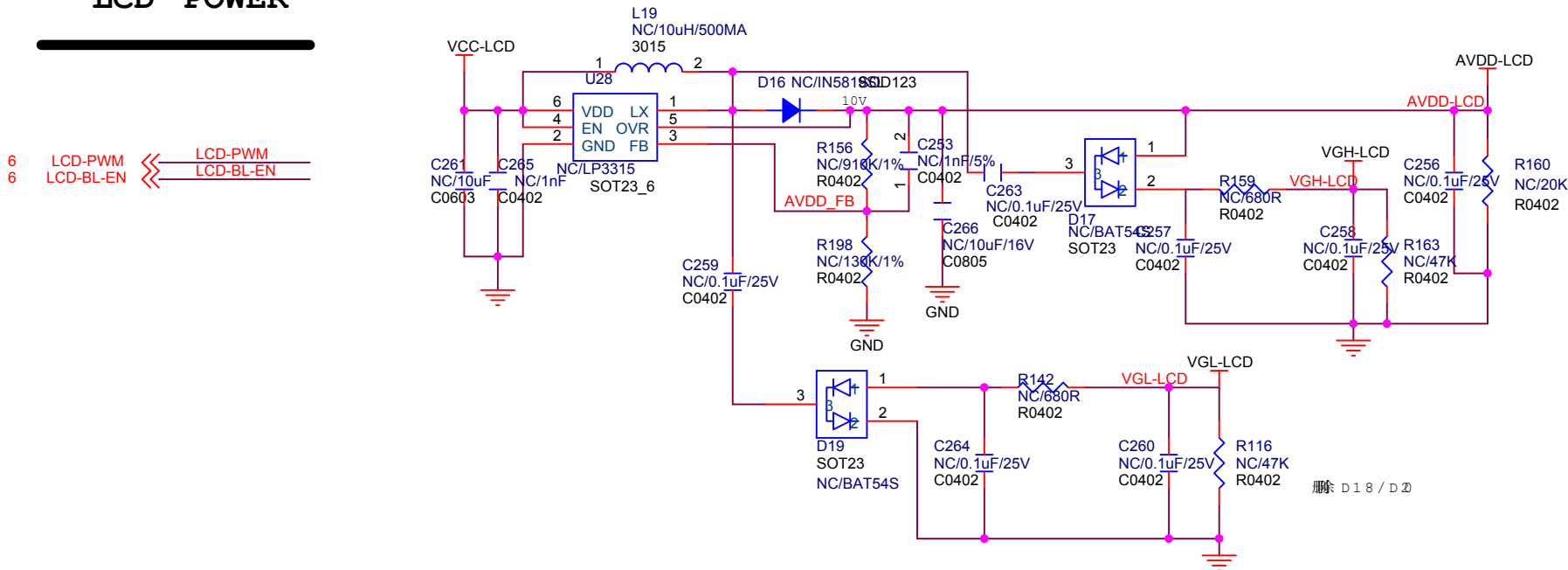

Backlight

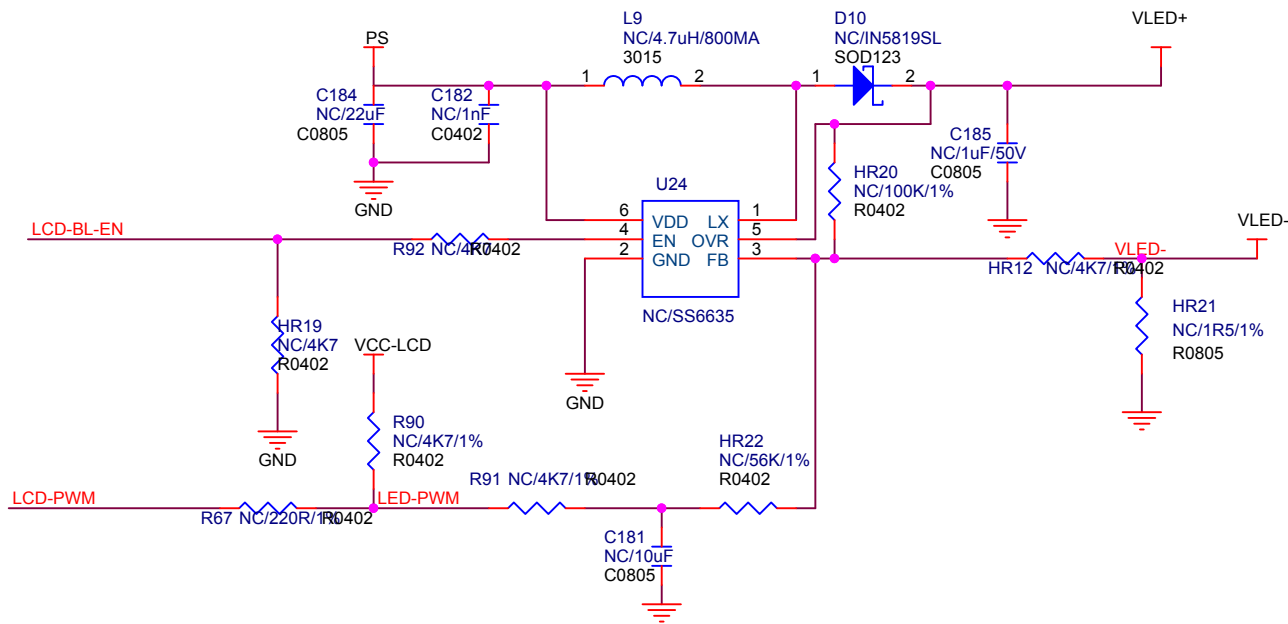

删除 D18 / D20

<i>Pine A64</i>	
Title	PINE A64 512MB
Document Number	LCD POWER
Size A4	Rev V1.2
Date: Thursday, December 24, 2015	Sheet 14 of 19

WIFI+BT

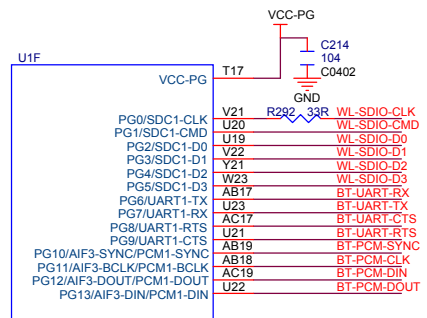

A64

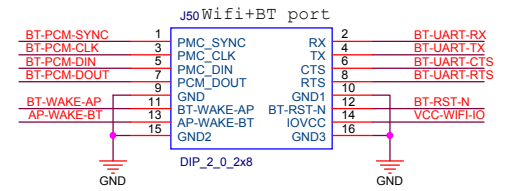
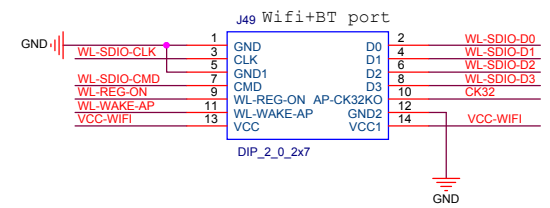
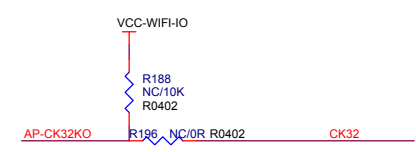
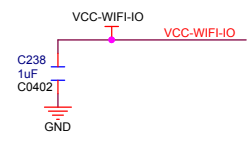
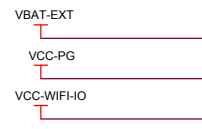

CTP

IR

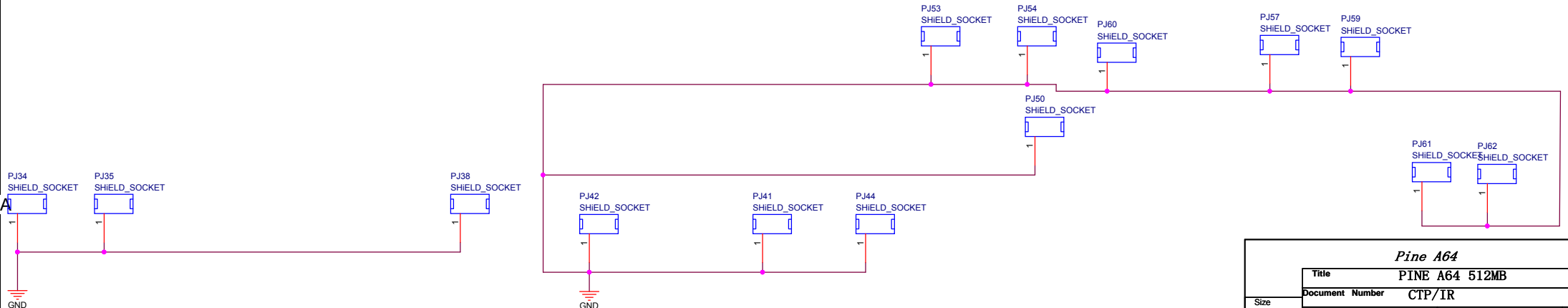
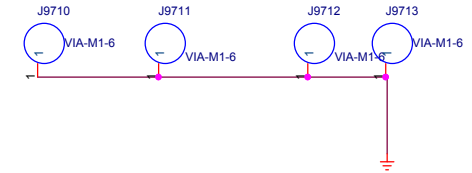
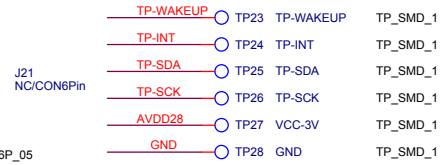
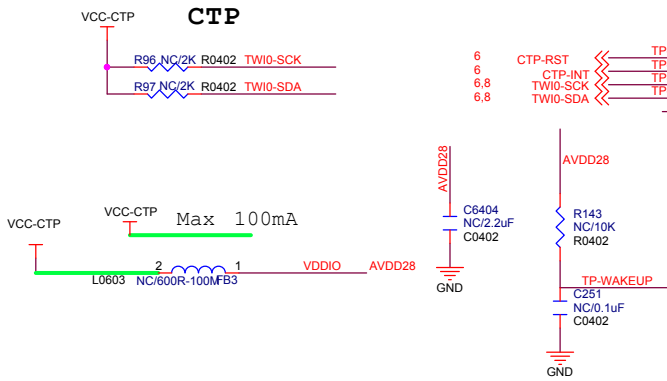
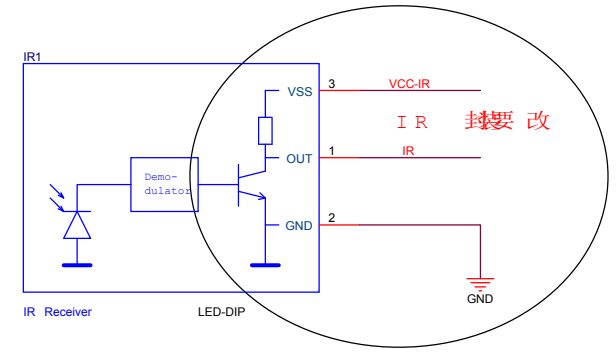
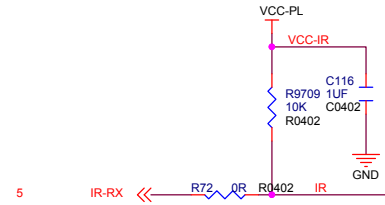

Pine A64			
Title		PINE A64 512MB	
Document Number		CTP/IR	
Size	A3	Date:	Thursday, December 24, 2015
Sheet	16	of	19
Rev	V1.2		

PI-2 bus

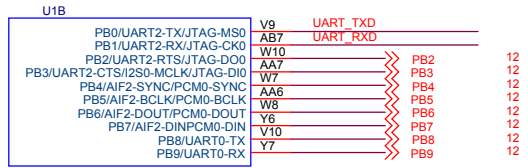

A64

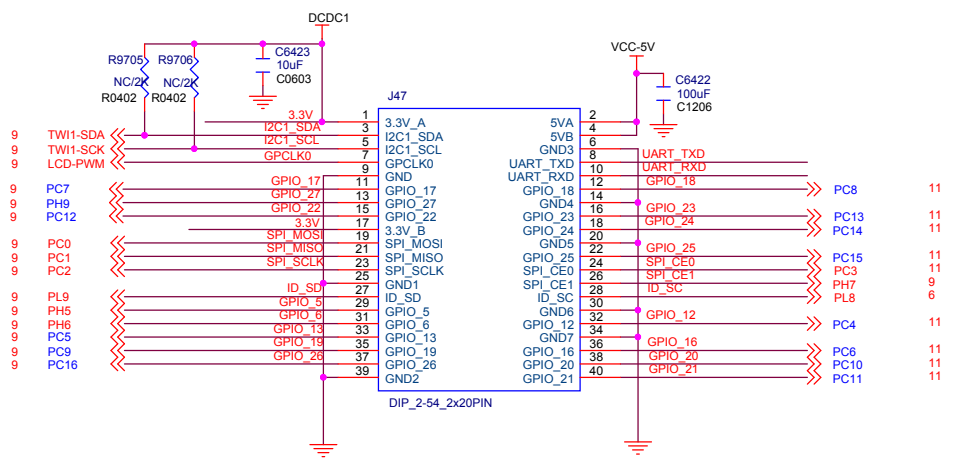

GMAC-3V

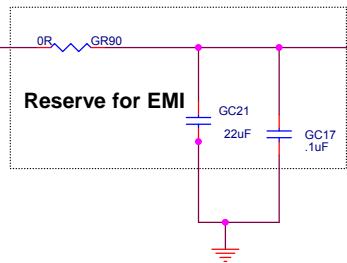

PHY_VDD33

PHY_AVDD33

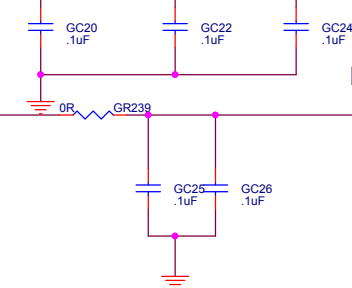

3.3/2.5V RGMII Power

PHY_VDD33

PHY_VDD25

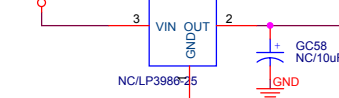

Reserve for 2.5V RGMII power (if MAC support 2.5V RGMII)

R80 for 3.3V RGMII
R81 for 2.5V RGMII (From 3.3-2.5V LDO)
R82 for 2.5VRGMII (From ACR 2.5V)
RTL8201FN/EN:GR81(NC) GR82(NC)

For EMI GC27,GC28 must close to pin15 and pin21

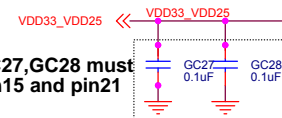

PHY_VDD33

PHY_VDD25

VDD25

PHY_AVDD10

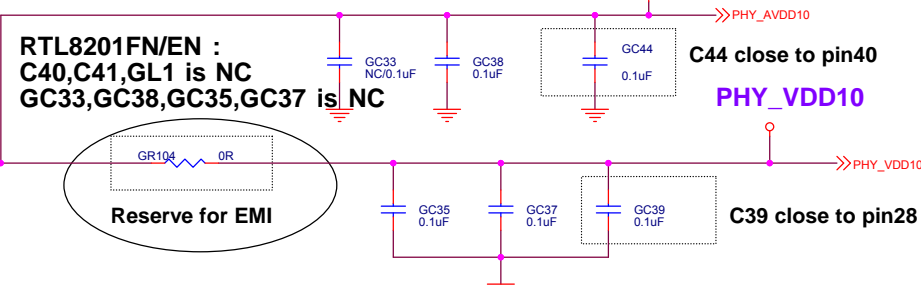

RTL8201FN/EN :
C40,C41,GL1 is NC
GC33,GC38,GC35,GC37 is NC

C44 close to pin40

PHY_VDD10

C39 close to pin28

RTL8211CN/D/E	GL1	C56	U10	GR65	GR66	GR122	GC41/GC57
Enable switching regulator	○	○	✗	○	✗	✗	○
Disable switching regulator	✗	✗	○	✗	○	○	✗

Note 1: The Trace length between GL1 and Pin 48 must be within 0.5 cm. GC40 and GC41 to G L1 must be within 0.5cm.

RTL8211D/8211CN:GC40 22uF(X5R)
RTL8211E: GC40 4.7uF(X5R)

C40 close to L1

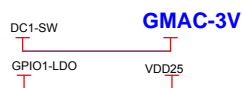

VDDREG

RTL8211D/8211CN: L1=4.7uH
RTL8211E: L1= 2.2uH

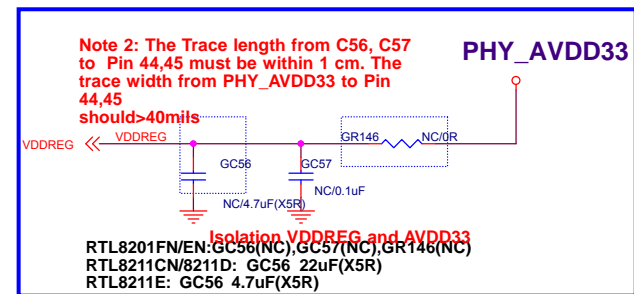

Note 2: The Trace length from C56, C57 to Pin 44,45 must be within 1 cm. The trace width from PHY_AVDD33 to Pin 44,45 should >40mils

PHY_AVDD33

Isolation VDDREG and AVDD33
RTL8201FN/EN:GC56(NC),GC57(NC),GR146(NC)
RTL8211CN/8211D: GC56 22uF(X5R)
RTL8211E: GC56 4.7uF(X5R)

External Power Source

U10,GC69,GC68, GR122,GR120 and GR121 are only used by 8211CN/8211D/8211E application when switching regulator is disabled. For other applications, please remove them.

RESERVE

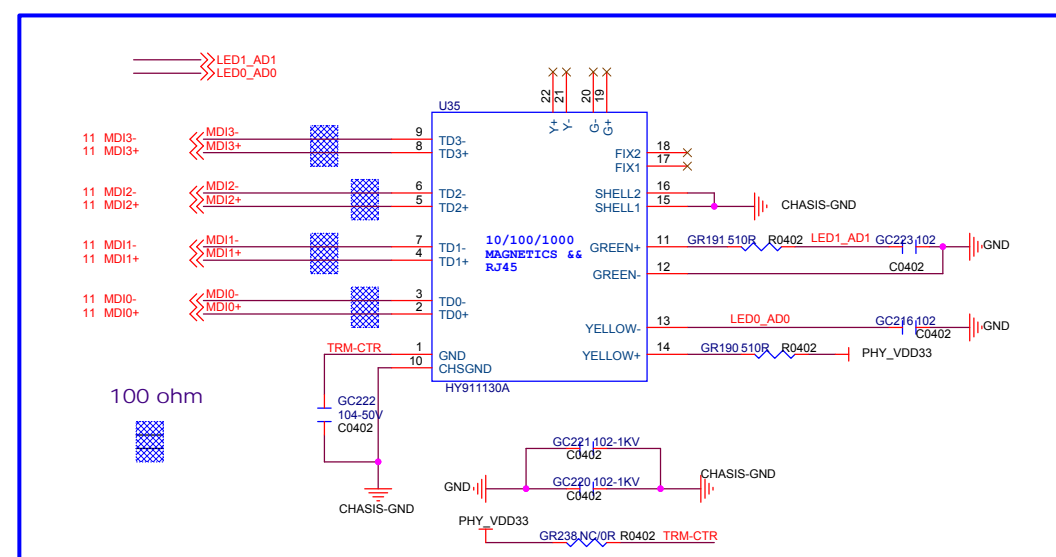

Pine A64			
Title	PINE A64 512MB		
Document Number	EMAC/GMAC		
Size	A3	Sheet	18 of 19
Date:	Wednesday, December 23, 2015	Rev	V1.2

